

LENKERERHÖHUNG

handlebar riser | Rehausseur de guidon | Elevador de manillar | Riser del manubrio

Art.-Nr. 41973-001



LEGENDE/KEY/FILE LÉGENDE

- Anbau Tipp**
Fitting tip
Astuce de montage
- Achtung**
Attention
Attention
- Vergößerung**
Magnification
Grossissement
- Montagepaste**
Fitting lubricant
Lubrifiant de montage

- Schraube**
Screw
Vis
- Schraubensicherung**
Thread locking fluid
Freiniflets
- Drehmoment**
Torque
Torque
- Reiniger**
Cleaner
Nettoyant



#	Bauteil component composant	DE Die Farben der Abbildungen dienen nur der Veranschaulichung. EN The colors are for illustrating purposes only. FR Les couleurs utilisées sont à titre indicatif seulement.	DIN	ISO	Menge quantity quantité
1	Zylinderschraube / Cylinder screw	M8x75 (Torx)	912Z	4762	4
2	Lenkererhöhung (rechte Seite) / Handlebar riser (right side)				1
3	Lenkererhöhung (linke Seite) / Handlebar riser (left side)				1
4	Schraubensicherung / Thread locking fluid				1

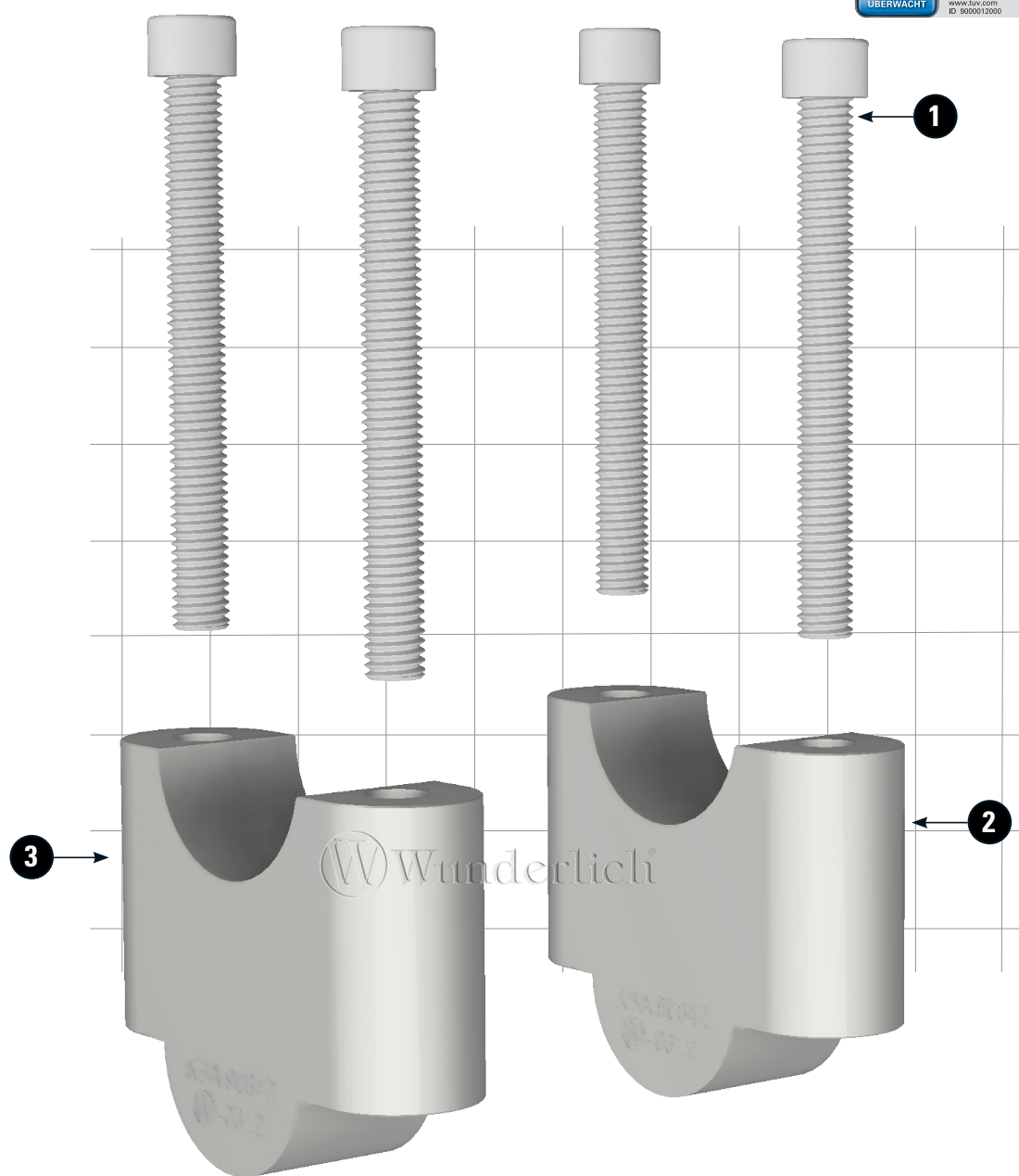

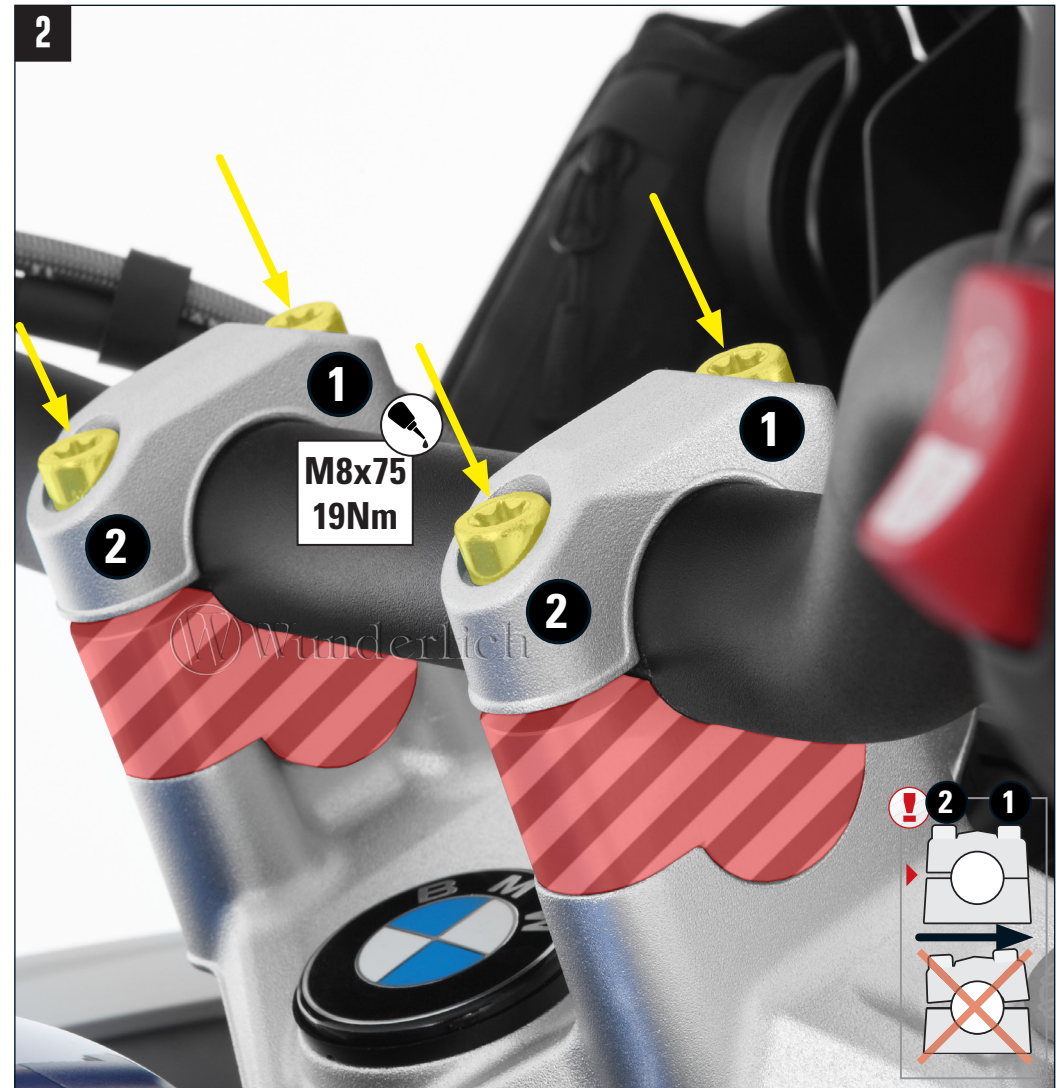

Vor der Montage die Verkleidung mit einer Tankschutzdecke schützen. Lenker demontieren und nach hinten ablegen.

SCHRAUBEN DER REIHE NACH FESTZIEHEN 1-2. LENKUNG AUF FREIGÄNGIGKEIT PRÜFEN !

Protect the fairing with a tank cover before fitting. Remove the handlebars and place them to the rear.

Tighten the screws in sequence 1-2. Check the steering for unobstructed movement.

Protégez le carénage à l'aide d'une housse de réservoir avant de procéder au montage. Retirer le guidon et le placer à l'arrière.

Serrez les vis dans l'ordre 1-2. Vérifiez la liberté de mouvement de la direction.