

SCHUTZPAD

Protection pad | Almohadilla antiarañazos | Patin de ponçage | Tampone scorrevole

Art.-Nr: **35931-30X**



LINKE SEITE

Left side
côté gauche

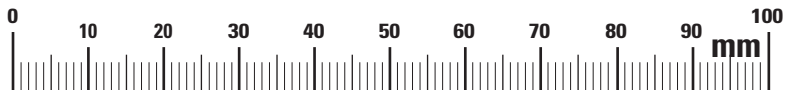
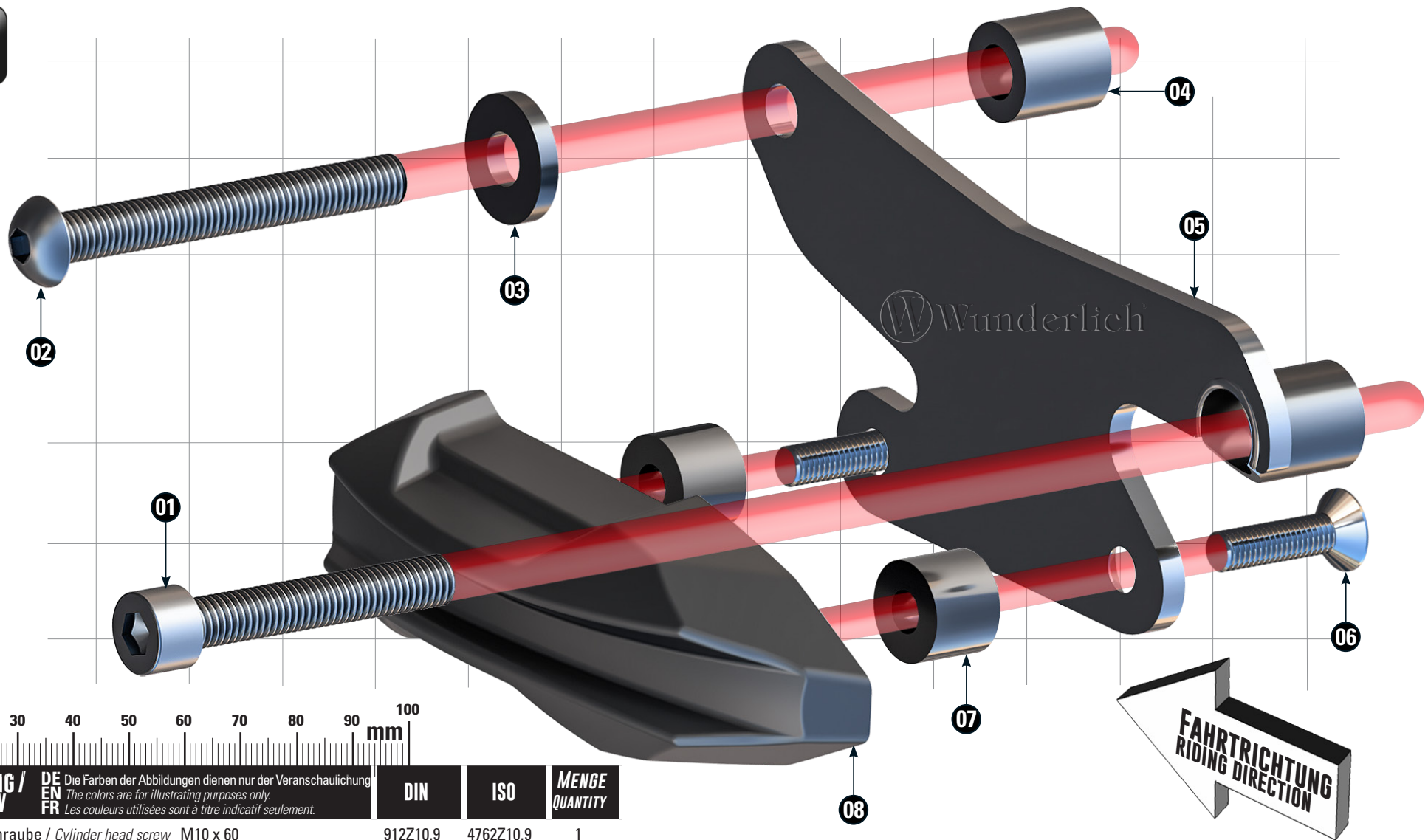

#	BEZEICHNUNG / DESCRIPTION	DE EN FR	Die Farben der Abbildungen dienen nur der Veranschaulichung. The colors are for illustrating purposes only. Les couleurs utilisées sont à titre indicatif seulement.	DIN	ISO	MENGE QUANTITY
1	Zylinderkopfschraube / Cylinder head screw M10 x 60			912Z10.9	4762Z10.9	1
2	Linsenkopfschraube / lens head screw M10 x 80			7380Z10.9	7380Z10.9	1
3	U-Scheibe / Washer M10			7349A2	8752A2	1
4	Hülse / Sleeve DØ 19,6 - dØ 10,8 - h 20,0mm					1
5-8 Vormontiert / 5-8 Pre-mounted						
5	Tragblech / Supporting plate					1
6	Senkkopfschraube / Countersunk screw M8 x 30			7991A2	7991A2	2
7	Hülse / Sleeve DØ 20,0 - dØ 8,5 - h 15,0mm					2
8	Schutzpad linke Seite / Pad left side					1

LEGENDE/KEY/FILE LÉGENDE

Anbau Tipp
Fitting tip
Astuce de montage

Achtung
Attention
Attention

Vergrößerung
Magnification
Grossissement

Montagepaste
Fitting lubricant
Lubrifiant de montage

Schraube
Screw
Vis

Schraubensicherung
Thread locking fluid
Freinfiets

Drehmoment
Torque
Torque

Reiniger
Cleaner
Nettoyant

01 **LINKE SEITE**
Left side
côté gauche

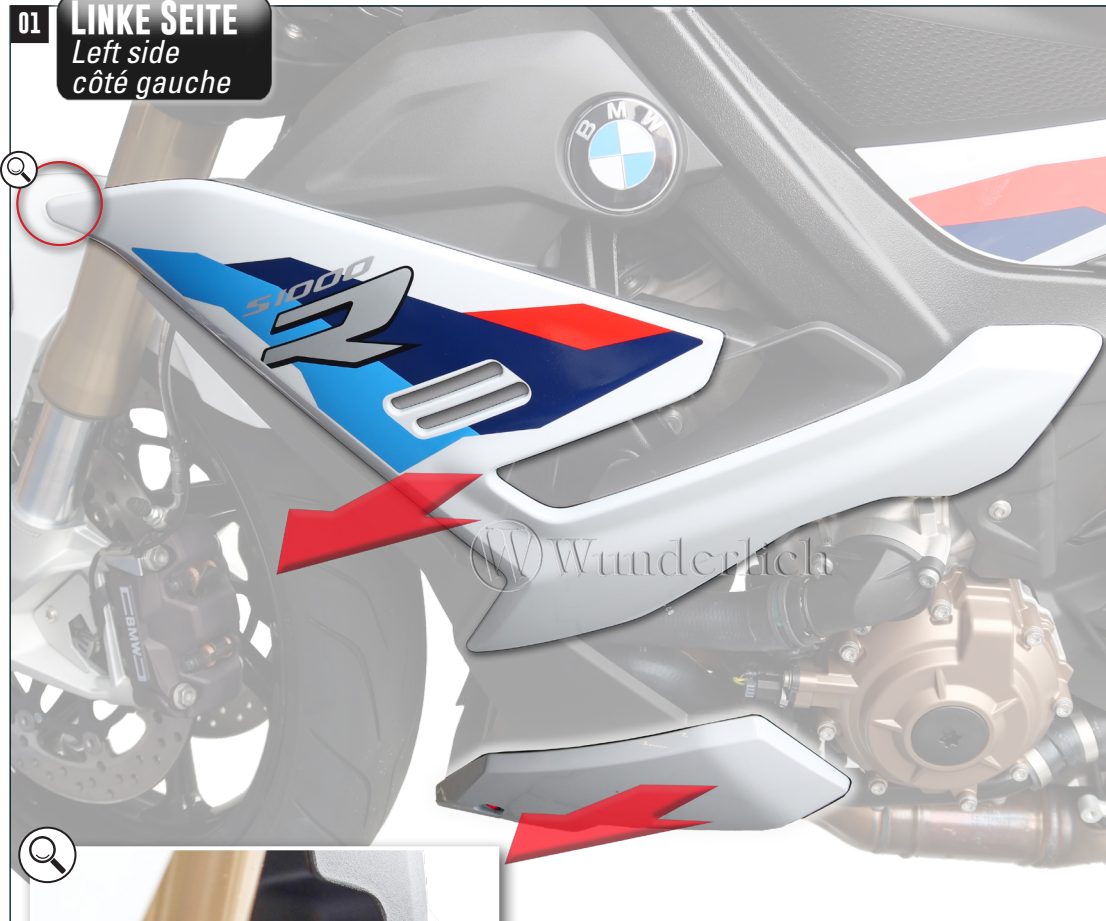

orig.
BMW
2Nm



orig.
BMW
2Nm



VERKLEIDUNG LÖSEN UND SCHUTZPAD MONTIEREN. GEBEBENENFALLS MÜSSEN SIE DIE VERKLEIDUNG KOMPLETT DEMONTIEREN.
Loosen the fairing and install the protection pad. You may need to completely dismantle the fairing.
Desserrez le carénage et posez le tampon de protection. Il se peut que vous deviez démonter complètement le carénage.

DREHMOMENTE NM, ANZIEHREIHENFOLGE

Torques Nm, sequence | Couples Nm, séquence

1: links an Rahmen
left to frame | de gauche à droite

60 NM

2: rechts an Rahmen
left to frame | droit au cadre

1. **30 NM**

2. **Weiterdrehwinkel 90°**
pretorque / pré-couple

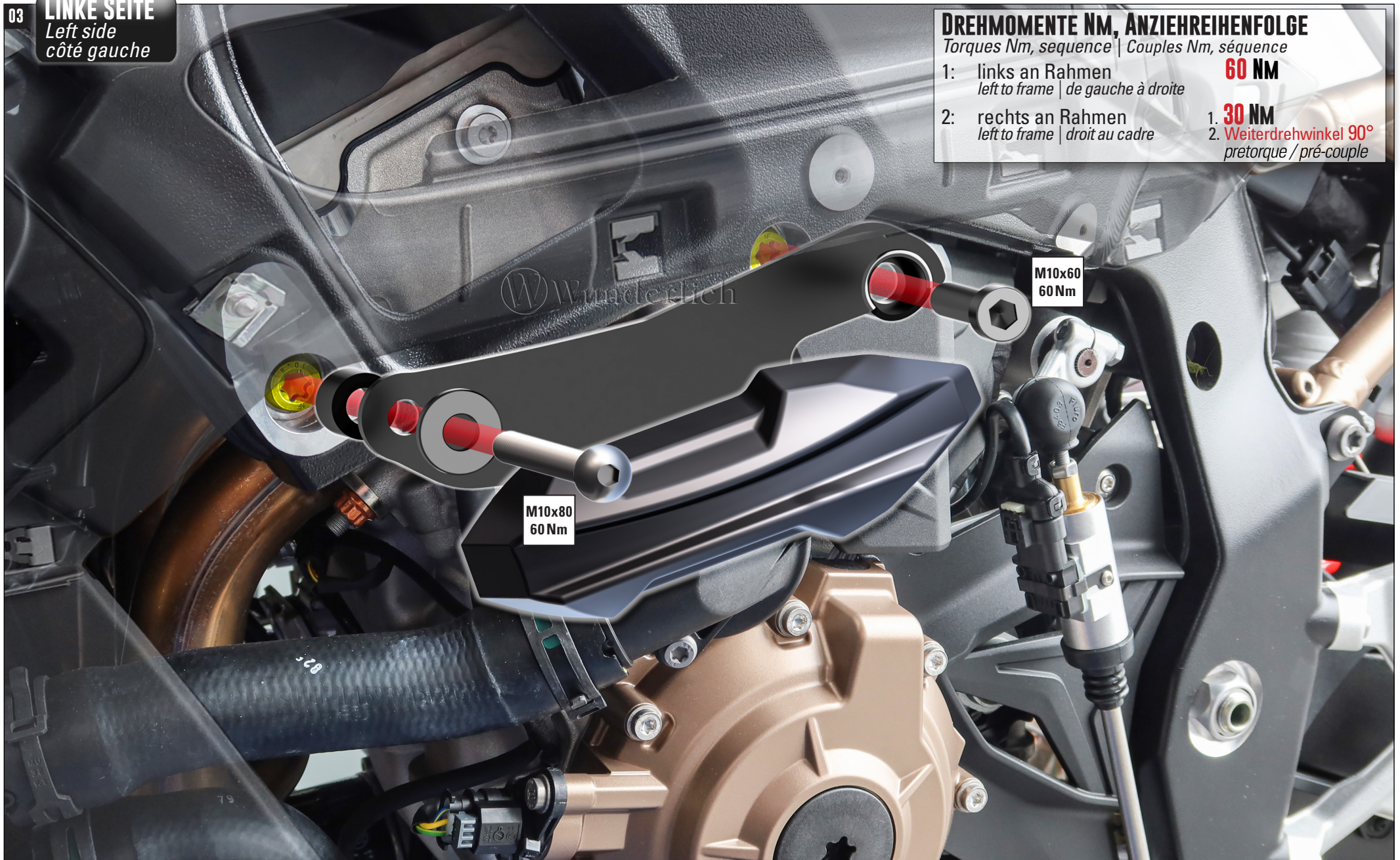

SEITENVERKLEIDUNG NACH DER MONTAGE DES SCHLEIFPADS, IN UMGEKEHRTER REIHENFOLGE ANBAUEN!

After fitting the slide pad, mount the side panel in reverse order.

Après avoir monté le patin de glissement, montez le panneau latéral dans l'ordre inverse!

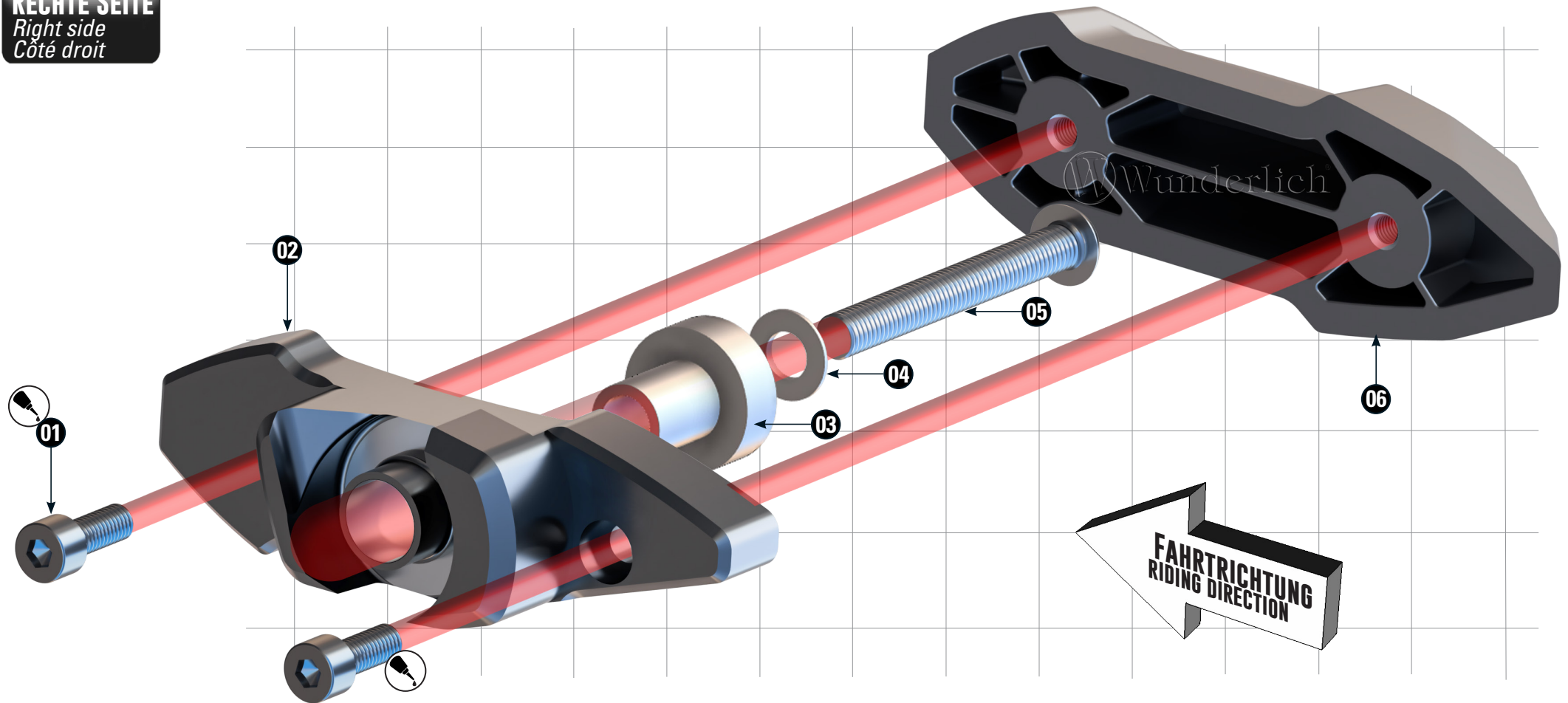
RECHTE SEITERight side
Côté droit

#	BEZEICHNUNG / DESCRIPTION	DE Die Farben der Abbildungen dienen nur der Veranschaulichung. EN The colors are for illustrating purposes only. FR Les couleurs utilisées sont à titre indicatif seulement.	DIN	ISO	MENGE QUANTITY
1	Zylinderkopfschraube / cylinder head screw	M8 x 20	912A2	912A2	2
2	Verbinder / Connector				1
3	Stufenhülse / Grade sleeve				1
4	U-Scheibe / Washer	M10	125A2	7089A2	1
5	Linsenkopfschraube / lens head screw	M10 x 80	7380Z10.9	7380Z10.9	1
6	Schutzpad rechte Seite / Pad right side				1
7	Schraubensicherung / Thread locking fluid				1



06



07

