

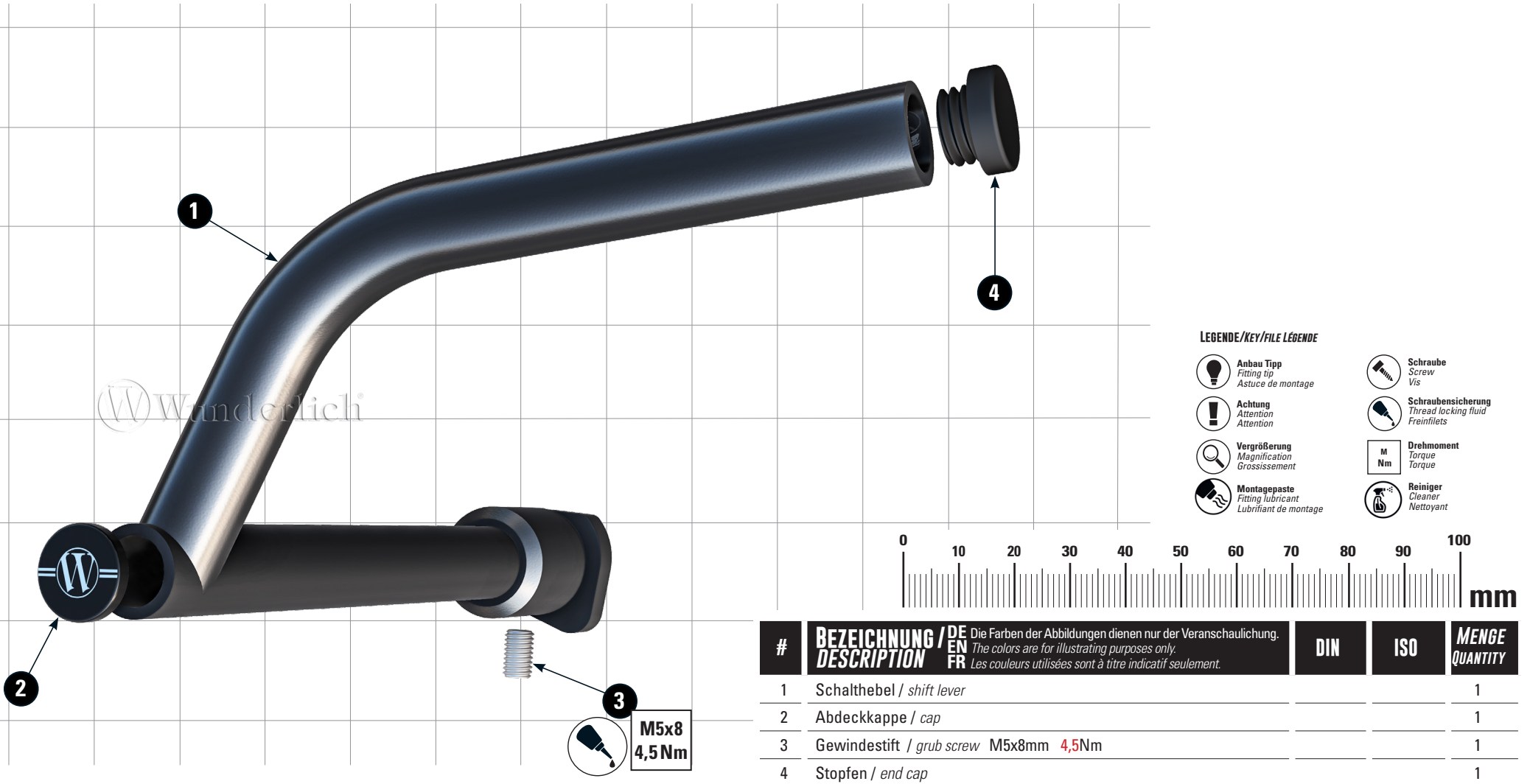







# SCHALTHEBEL

shift lever | levier de vitesse | palancas de cambio | leva del cambio

Art.-Nr: 18210-00x



## LEGENDE/KEY/FILE LÉGENDE

-  **Anbau Tipp**  
Fitting tip  
Astuce de montage
-  **Schraube**  
Screw  
Vis
-  **Achtung**  
Attention  
Attention
-  **Schraubensicherung**  
Thread locking fluid  
Freinfilets
-  **Vergrößerung**  
Magnification  
Grossissement
-  **Drehmoment**  
Torque  
Torque
-  **Montagepaste**  
Fitting lubricant  
Lubrifiant de montage
-  **Reiniger**  
Cleaner  
Nettoyant

#	BEZEICHNUNG / DESCRIPTION DE / EN / FR	Die Farben der Abbildungen dienen nur der Veranschaulichung. The colors are for illustrating purposes only. Les couleurs utilisées sont à titre indicatif seulement.	DIN	ISO	MENGE / QUANTITY
1	Schalthebel / shift lever				1
2	Abdeckkappe / cap				1
3	Gewindestift / grub screw	M5x8mm 4,5Nm			1
4	Stopfen / end cap				1

