

WANDHALTER

Suitcase holder | Titolare bagagli | Porte-bagages | Portaequipajes

Art.-Nr: **15902-00x**

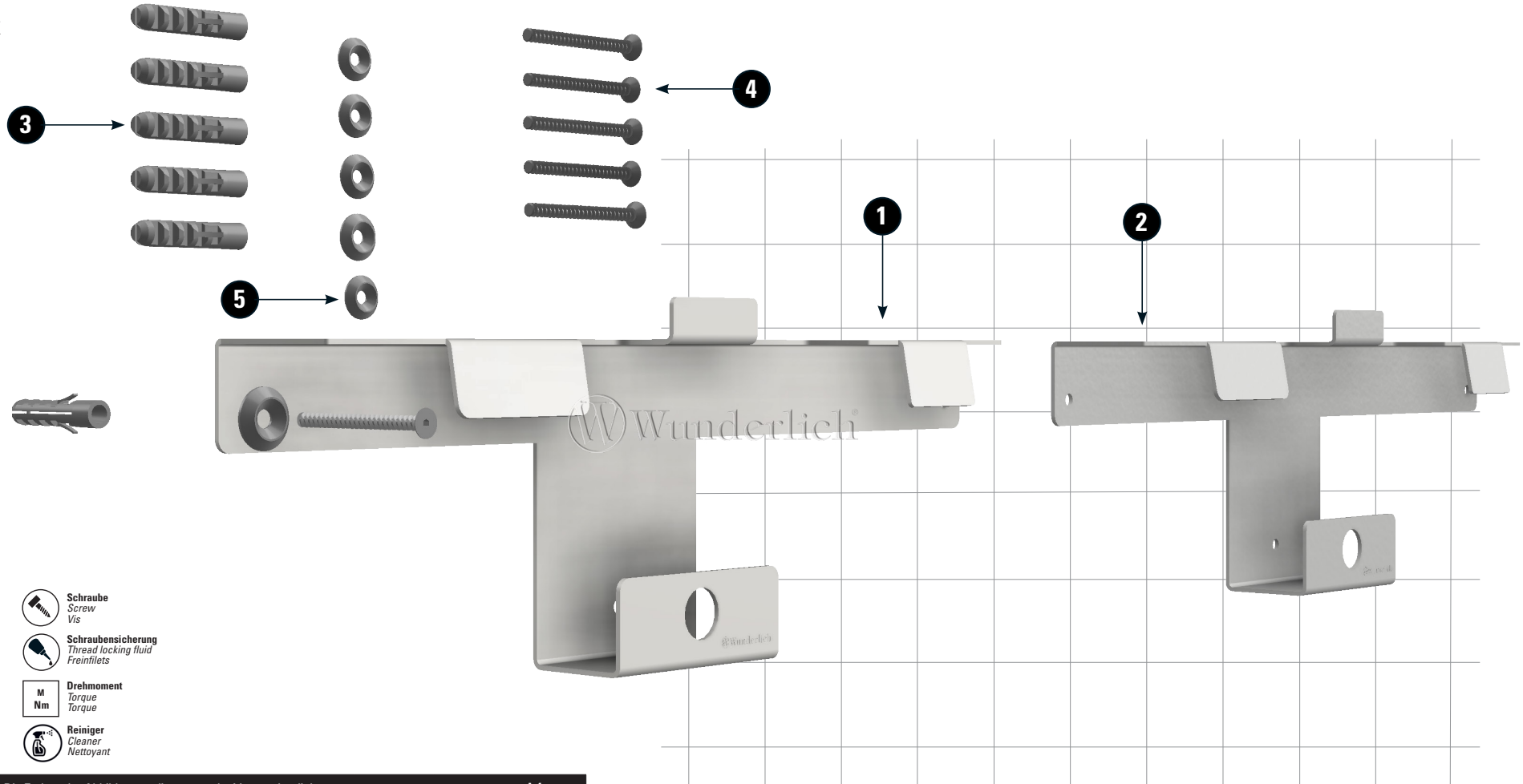

LEGENDE/KEY/FILE LÉGENDE



Anbau Tipp
Fitting tip
Astuce de montage



Achtung
Attention
Attention



Vergößerung
Magnification
Grossissement



Montagepaste
Fitting lubricant
Lubrifiant de montage



Schraube
Screw
Vis



Schraubensicherung
Thread locking fluid
Freiniflets



M Nm
Drehmoment
Torque
Torque



Reiniger
Cleaner
Nettoyant

#	Bauteil component composant	DE Die Farben der Abbildungen dienen nur der Veranschaulichung. EN The colors are for illustrating purposes only. FR Les couleurs utilisées sont à titre indicatif seulement.	DIN	ISO	Menge quantity quantité
1	Wandblech links / Wall plate left side				1
2	Wandblech rechts / Wall plate right side				1
3	Universaldübel / Dowel				6
4	Spaxschraube / Spax screw	M5 x 60			6
5	Rosette / Rosette				6



Bitte überprüfen sie, ob die beigelegten
Universaldübel für ihren Wandaufbau geeignet sind.
Halter so montieren, dass der Koffer in der Waage
hängt.

Koffer nur komplett entleert aufhängen. Sie können
den Koffer wie gewohnt abschließen.

*Please check whether the enclosed universal dowels are
suitable for wall mounting.*

Mount the holder so that the case hangs in the balance.

*Suspend the case only completely emptied. You can lock the
case as usual.*

*Veuillez vérifier si les chevilles universelles fournies
conviennent à votre structure murale.*

*Installez le support de manière à ce que le boîtier pende
horizontalement.*

*Ne raccrochez la valise que lorsqu'elle est complètement
vide. Vous pouvez verrouiller la valise comme d'habitude.*