

FUßRASTENSATZ >ERGO<

footrest | Reponse-pied | Estribera | Pedana

Art.-Nr: 25910-XXX

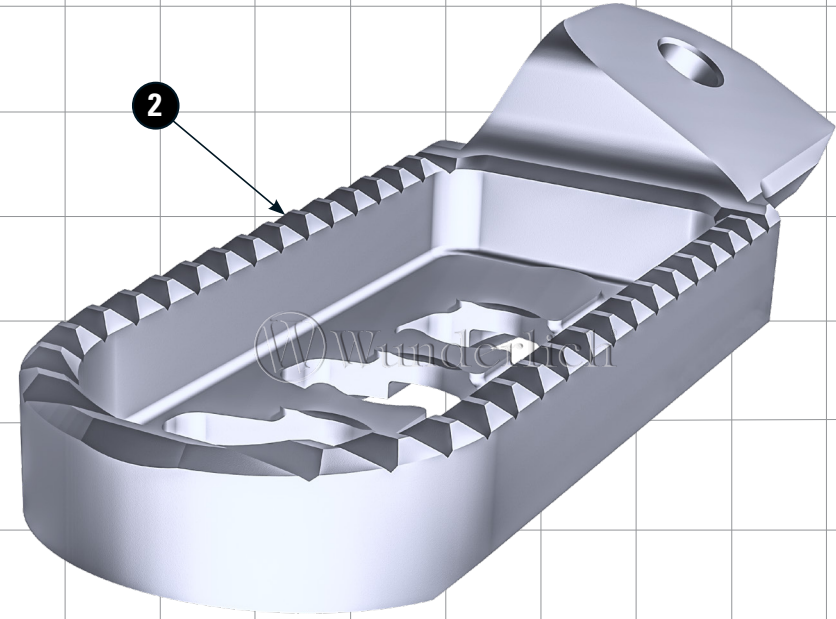
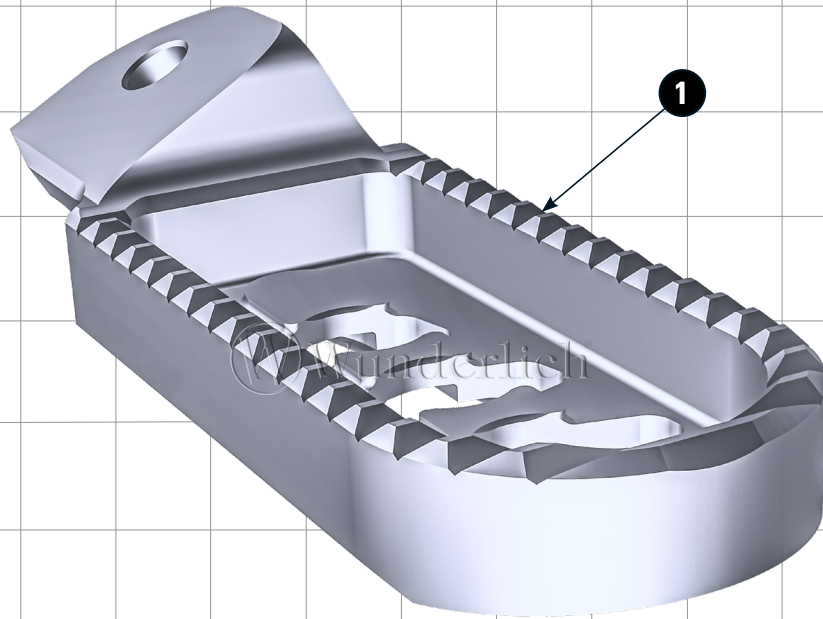

Wenn nötig, Schalt-/Bremshebel einstellen. Dabei ist auf die Freigängigkeit des Hinterrades zu achten.

*Adjust the shift / brake lever if necessary. Make sure that the rear wheel moves freely.
Ajustez le levier de vitesse / frein si nécessaire. Assurez-vous que la roue arrière se déplace librement.*

Bei folgenden Modellen empfehlen wir unseren Fußbremshebel Tieferlegung.

*We recommend our foot brake lever lowering kit for the following models.
Nous recommandons abaissement pour pédale de frein à pied pour les modèles suivants.*
31430-313 für R1200/R1250 LC R / RS
25910-401 für F900R
25910-501 für F900XR

#	BEZEICHNUNG / DESCRIPTION DE Die Farben der Abbildungen dienen nur der Veranschaulichung. EN The colors are for illustrating purposes only. FR Les couleurs utilisées sont à titre indicatif seulement.	DIN	ISO	MENGE QUANTITY
1	Fußraste (links) / footrest (left side)			1
2	Fußraste (rechts) / footrest (right side)			1
3	Sicherungsclip / locking clip			2

LEGENDE/KEY/FILE LÉGENDE



Anbautipp
Fitting tip
Astuce de montage



Achtung
Attention
Attention



Vergrößerung
Magnification
Grossissement



Schraube
Screw
Vis



Schraubensicherung
Thread locking fluid
Freinfiles



M Nm
Drehmoment
Torque
Torque



Montagepaste
Fitting lubricant
Lubrifiant de montage

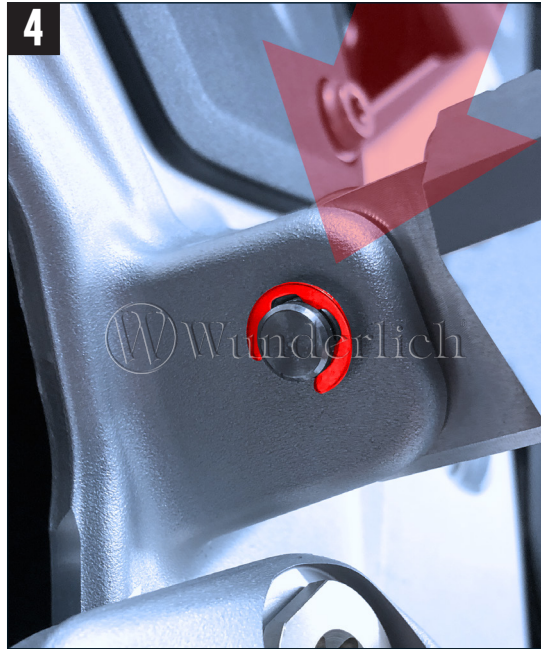
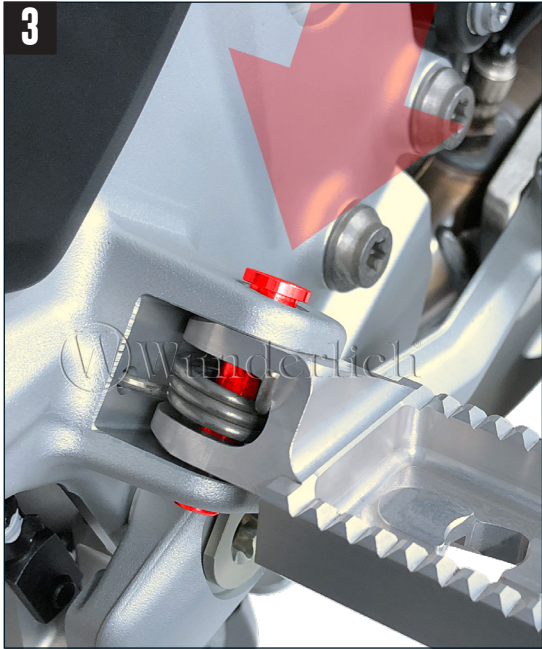
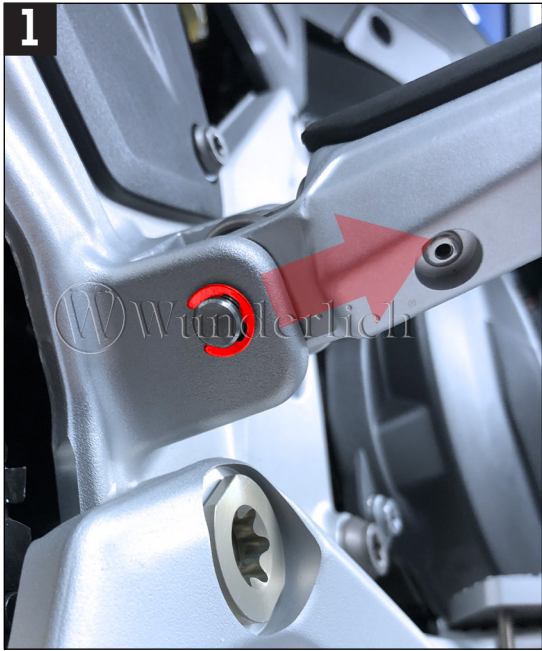

S1000XR 2020-



LINKE SEITE
LEFT SIDE
CÔTÉ GAUCHE

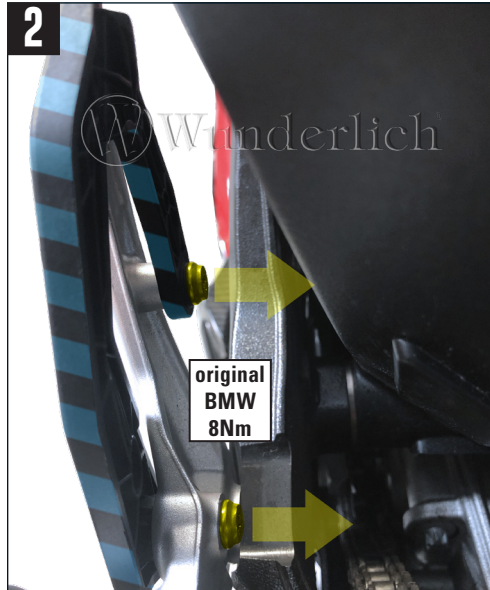
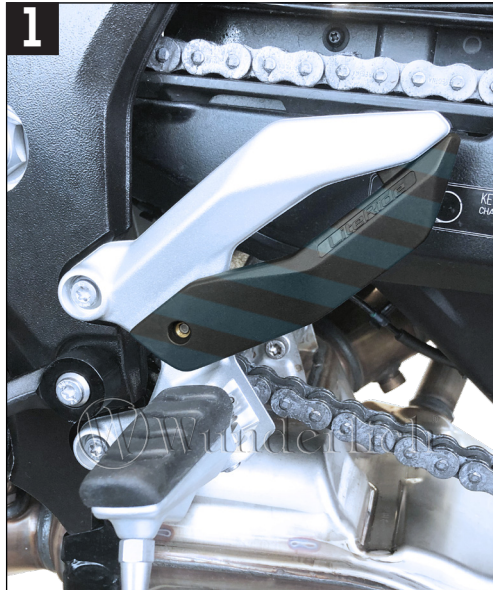

RECHTE SEITE
RIGHT SIDE
CÔTÉ DROIT

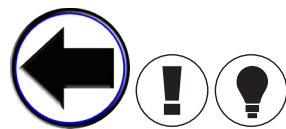
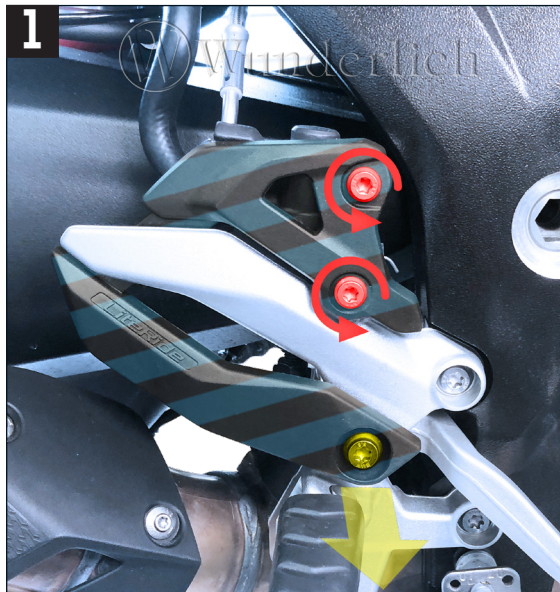

**Die untere Schraube entfernen.
Die oberen Schrauben nur lösen.**

*Remove The lower screw.
Just loosen the top screws
but do not remove completely.*

*Retirer la vis inférieure.
Desserrer juste les vis du
dessus.*

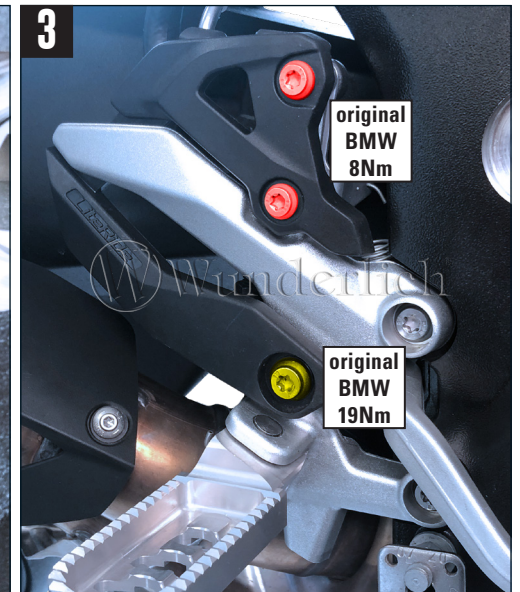

F900XR



**LINKE
SEITE**
LEFT
SIDE
CÔTÉ
GAUCHE

