

# HANDPROTEKTOR

Hand guard | Protectores de manos | Protège-mains | Paramani

Art.-Nr: 42006-00x

**In Kombination mit der Verkleidungsscheibe 42004-00X benötigen Sie den Montagesatz 42004-010.**

*In combination with the windshield 42004-00X you need the mounting kit 42004-010.*

*En combinaison avec le pare-brise 42004-00X, vous avez besoin du kit de montage 42004-010.*

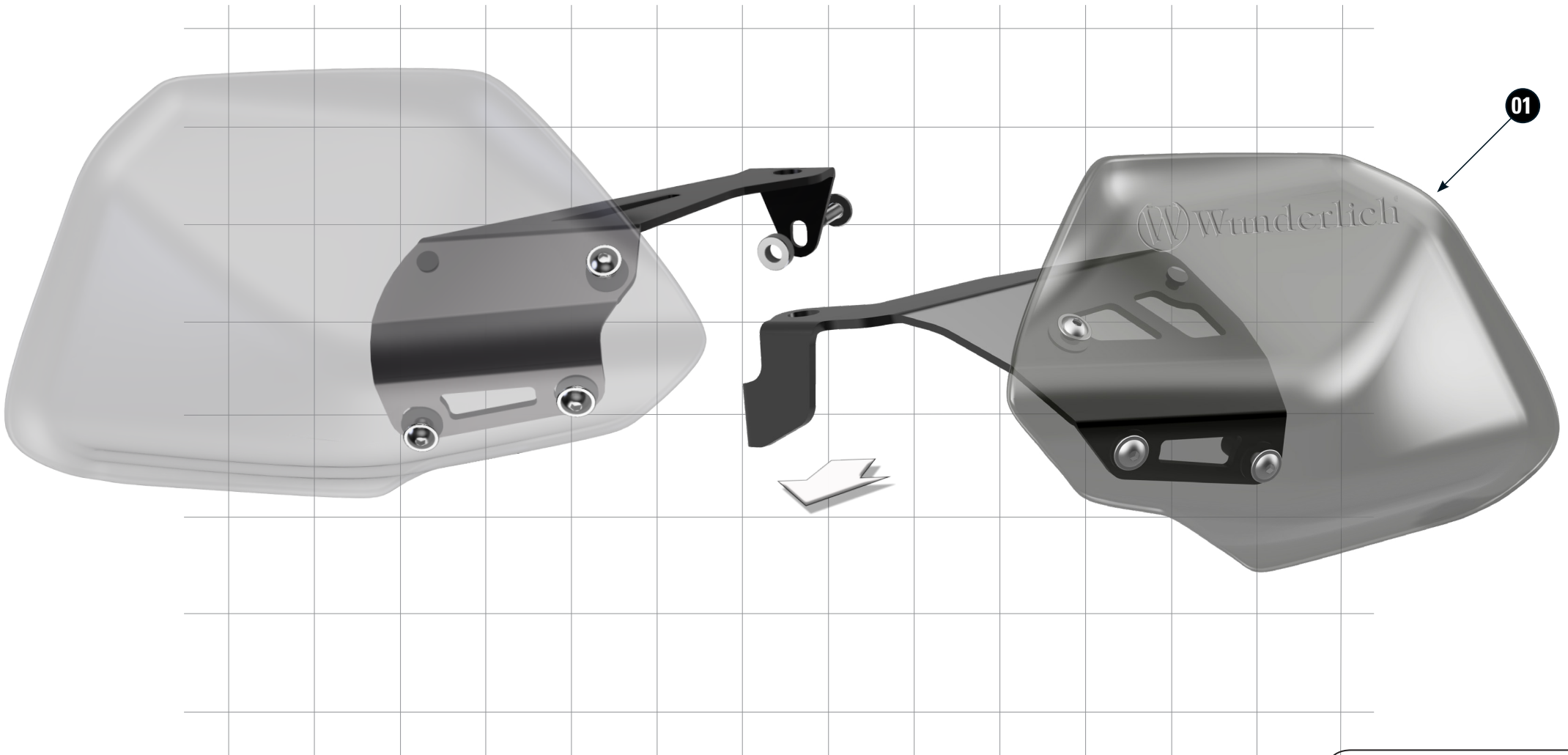

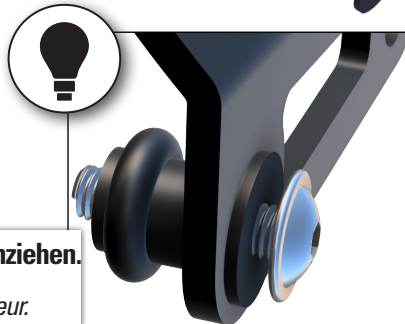
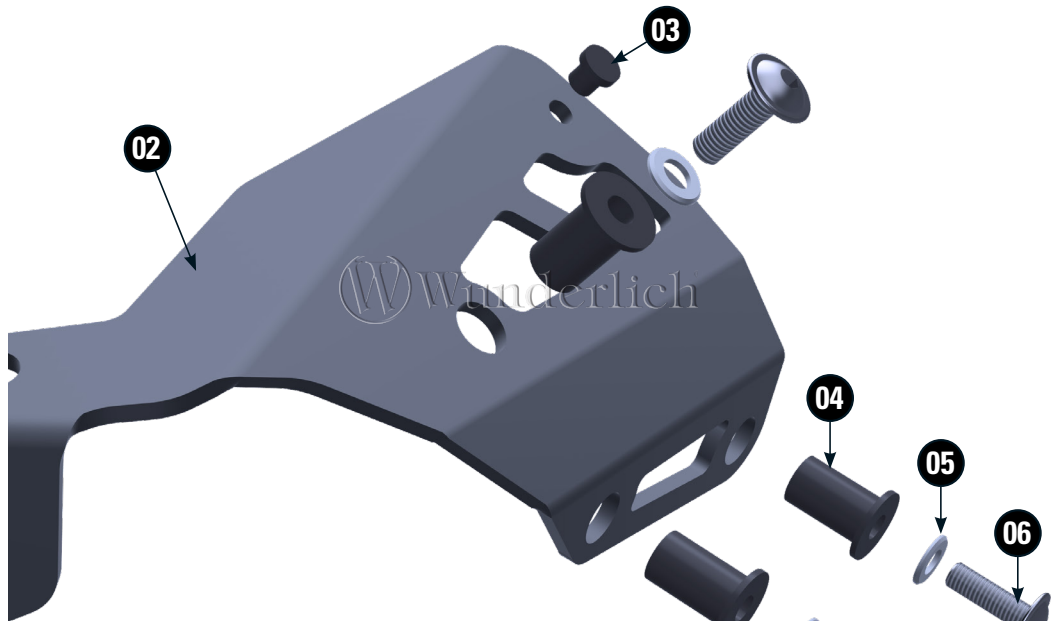

**Einsteckmutter 1x ohne Protektor anziehen.**  
Tighten the speed nut 1x without protector.  
Serrer l'écrou de vitesse 1x sans protecteur.

**LEGENDE/Key/Légende**

**Anbau Tip**  
Fitting tip  
Astuce de montage

**Achtung**  
Attention  
Attention

**Vergrößerung**  
Magnification  
Grossissement

**Montagepaste**  
Fitting lubricant  
Lubrifiant de montage

**Schraube**  
Screw  
Vis

**Schraubensicherung**  
Thread locking fluid  
Freinfiles

**M**  
**Nm** **Drehmoment**  
Torque  
Couple de serrage

#	BEZEICHUNG / DE DESCRIPTION	FR	DIN	ISO	MENGE QUANTITY
1	Handprotektor (linke u. rechte Seite) / Hand guard (left and right Side)				2
2	Grundhalter (linke u. rechte Seite) / Basic bracket (left and right Side)				2
3	Gummistopfen / Rubber stoppers				2
4	Einsteckmutter / Insert nuts				6
5	U-Scheibe PVC/ Washer PVC				6
6	Linseflanschschraube / Lens head screw M5x18		7381SA2	7381SA2	6
7	Hülse/ Sleeve DØ 12,0 - dØ 6,5 - h 7,0mm				2
8	Linseflanschschraube / lens head screw M6x30		7381SA2	7381SA2	2
9	Moosgummi / Foam rubber				5cm
10	Linsekopfschraube / Lens head screw M5x25		7380A2	7380A2	1
11	Hülse/ Sleeve DØ 10,0 - dØ 5,3 - h 8,0mm				1



4



M5  
1,5Nm

**Handprotektoren vormontieren.**  
*Preassemble hand protectors.*  
*Pré-assembler les protections des mains.*

5



ORIG. POS.

10

11

M5x25  
3Nm

6



STEP 1

STEP 2

M10  
22Nm

**Linksgewinde!**  
*Left-hand thread!*  
*Filetage à gauche!*



M6x30  
8Nm



**Montagerihenfolge einhalten.**  
*Mounting sequence.*  
*Ordre de montage.* **STEP 1-2**

7



**Lenkerverkleidung in umgekehrter Reihenfolge montieren!**  
*Mount handlebar cover in reverse order.*  
*Montez le couvercle du guidon dans l'ordre inverse.*