

LENKER APEHANGER

Handlebar | Guidon | Manubrio | Manillar

Artikel-Nr.: **11800-000**

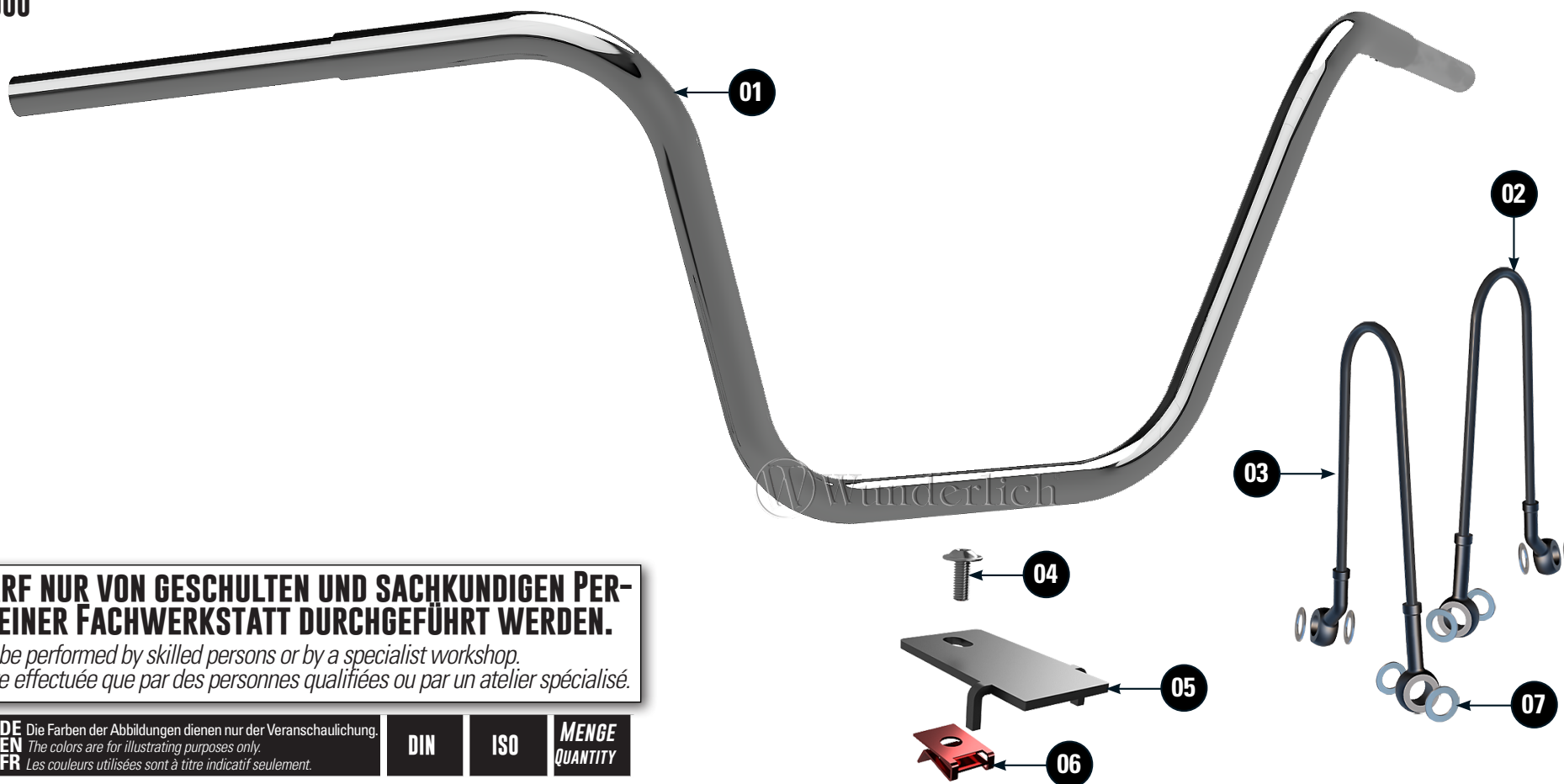

DIE MONTAGE DARF NUR VON GESCHULTEN UND SACHKUNDIGEN PERSONEN, ODER IN EINER FACHWERKSTATT DURCHFÜHRT WERDEN.

*Installation should only be performed by skilled persons or by a specialist workshop.
L'installation ne doit être effectuée que par des personnes qualifiées ou par un atelier spécialisé.*

#	BEZEICHUNG / DESCRIPTION	DE Die Farben der Abbildungen dienen nur der Veranschaulichung. EN The colors are for illustrating purposes only. FR Les couleurs utilisées sont à titre indicatif seulement.	DIN	ISO	MENGE QUANTITY
1	Lenker / Handlebar				1
2	Bremsleitung / Brake line				1
3	Kupplungsleitung / Clutch line				1
4	Linsenflanschschraube / Lens head screw M5 x 10		7381A2	7381	1
5	Halteblech / Retaining plate				1
6	Blechmutter / Sheet metal nut				1
7	Dichtringe / Sealing rings				8
8	Kabelverlängerung Blinker / Cable extension indikator				1

LEGENDE/KEY/FILE LEGENDE

Anbau Tipp
Fitting tip
Astuce de montage

Achtung
Attention
Attention

Vergrößerung
Magnification
Grossissement

Montagepaste
Fitting lubricant
Lubrifiant de montage

Schraube
Screw
Vis

Schraubensicherung
Thread locking fluid
Freinfilets

Drehmoment
Torque
Torque

Reiniger
Cleaner
Nettoyant



1 Der Reihenfolge nach demontieren!
Remove the parts in the order listed.
Retirez les pièces dans l'ordre indiqué.

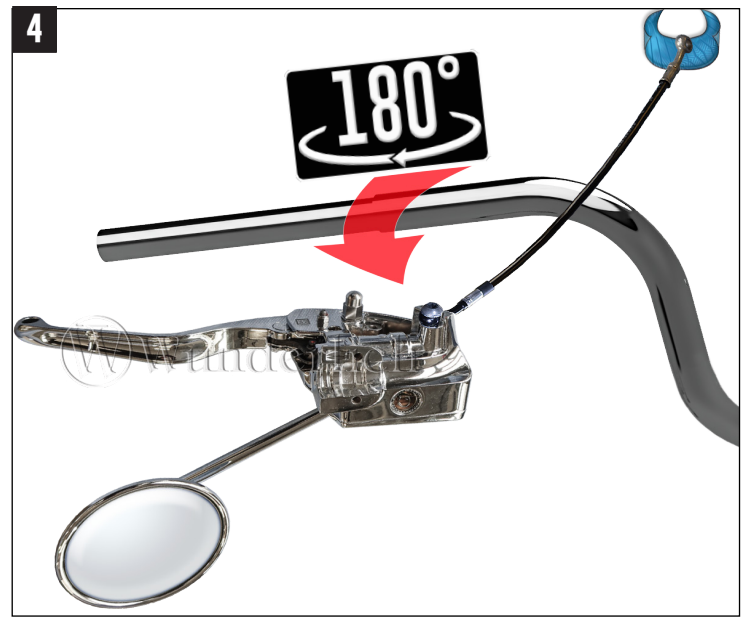
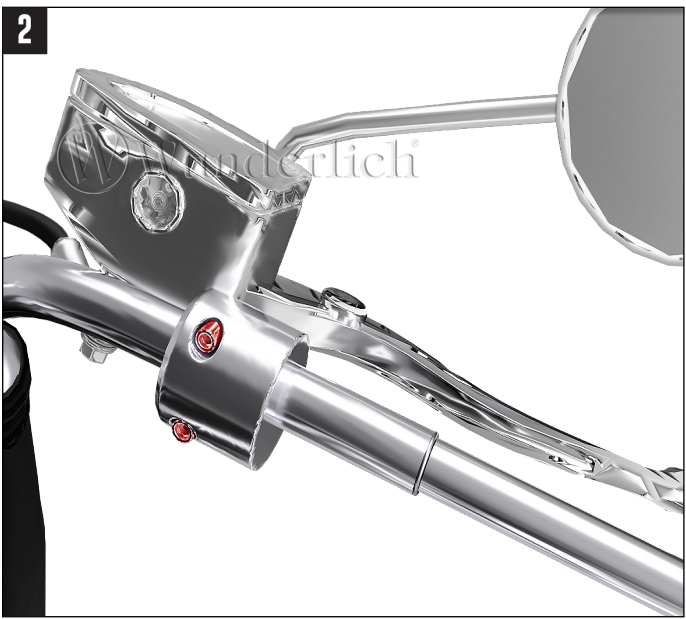
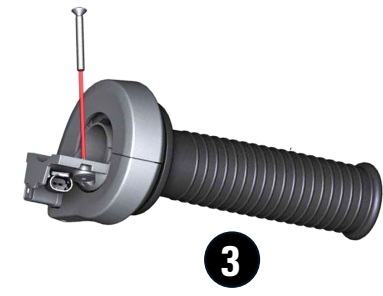
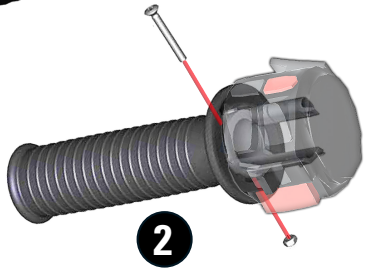
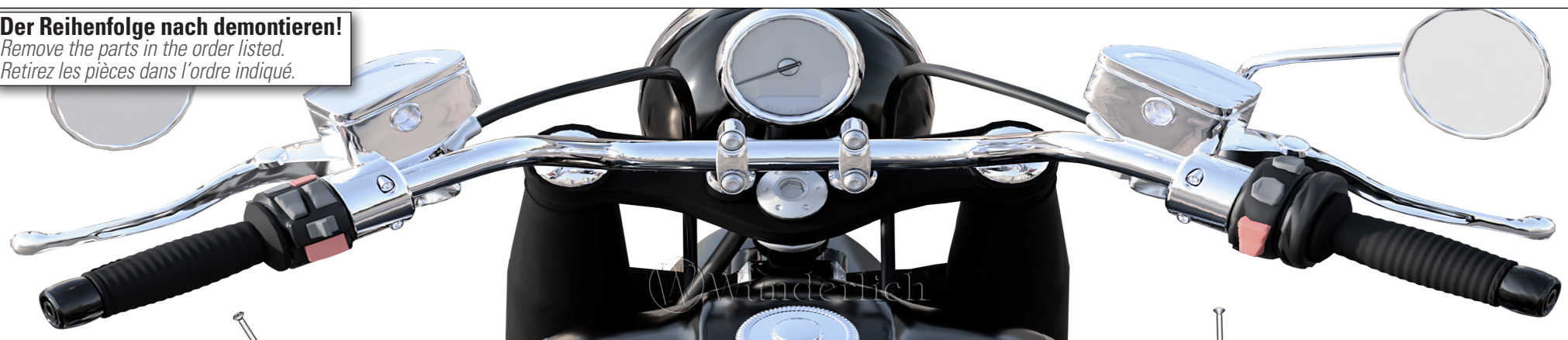

5

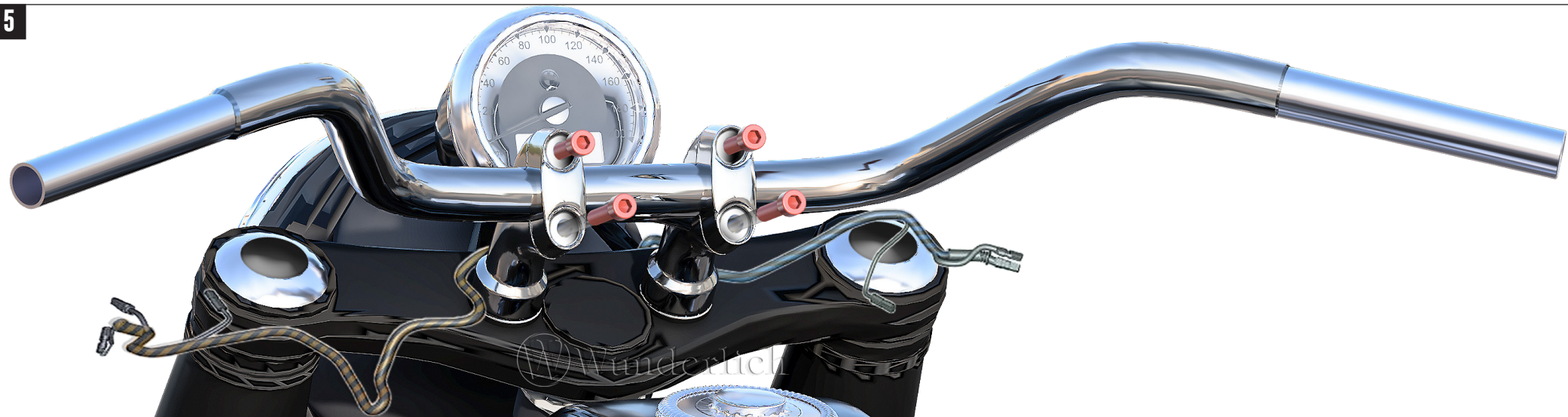

6



**GEHÄUSEABDECKUNGEN, ANSCHLÜSSE DES TANKS
UND TANK DEMONTIEREN.**

*Remove housing covers, tank connections and the tank.
Retirer les couvercles du boîtier, les raccords du réservoir et le réservoir.*

7



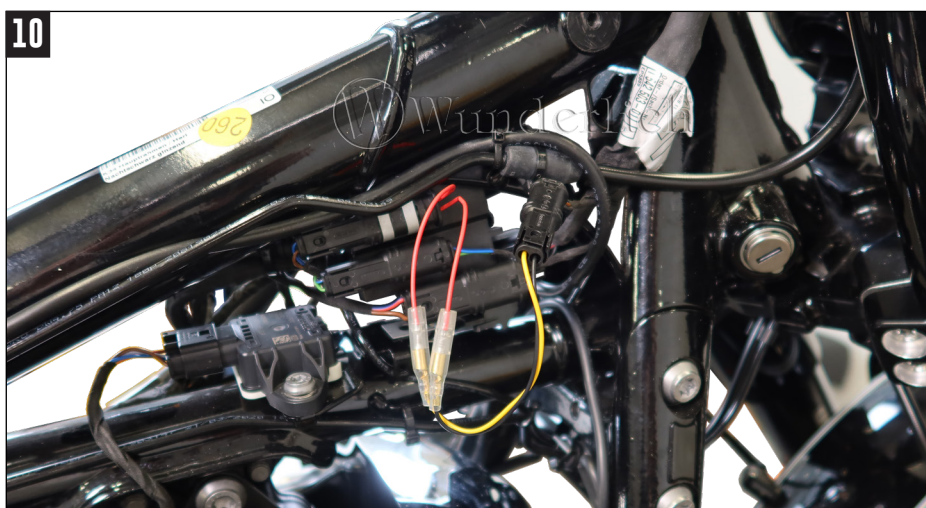
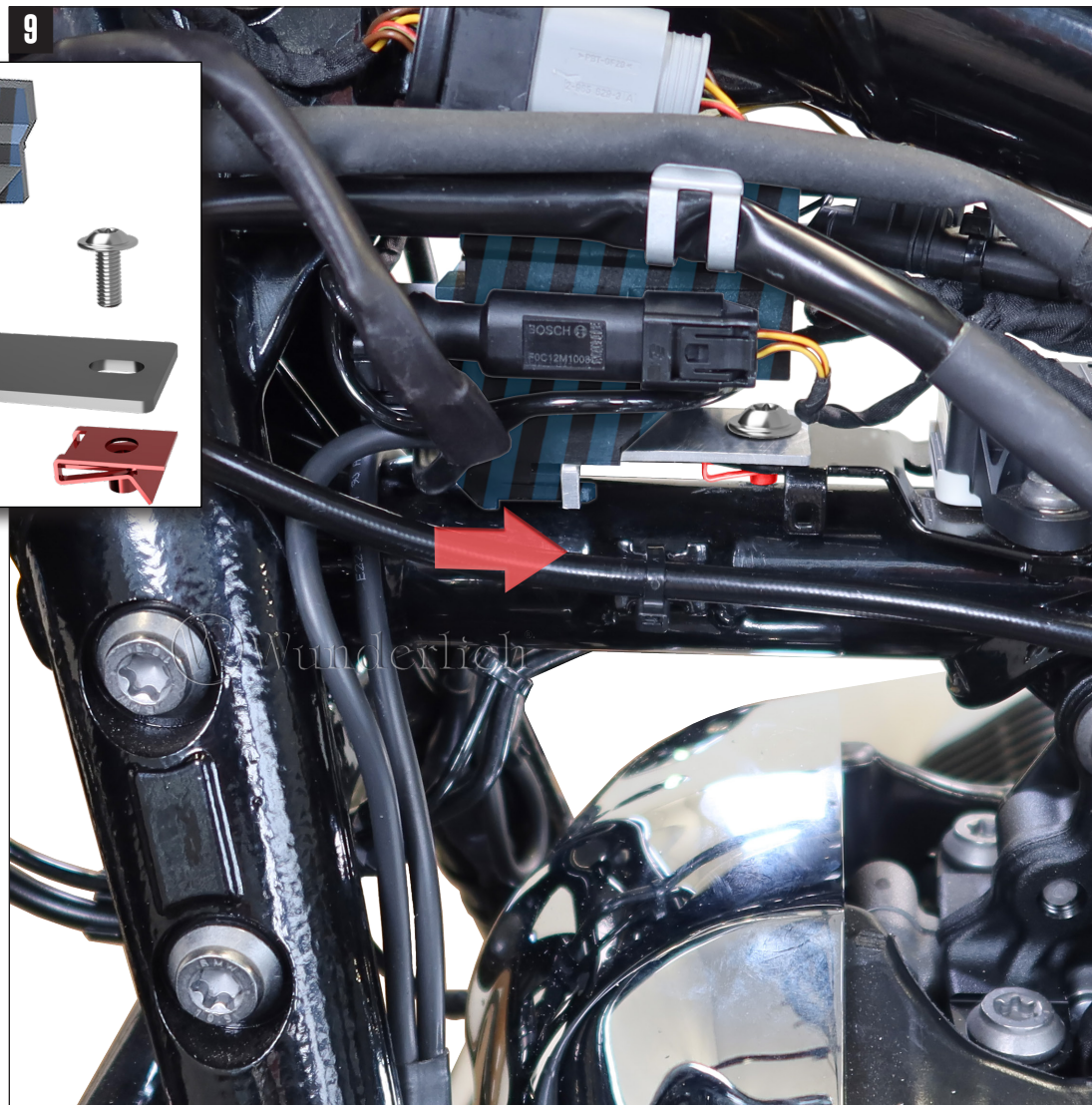

KABELFÜHRUNGEN OPTIMIEREN, GEGEBENENFALLS MIT DEN BEILIEGENDEN KABEL-ADAPTERN VERLÄNGERN (BILD 10). STECKERGEHÄUSE MITTELS BLECHHALTER VERLEGEN.

Optimise cable routing, extend with the enclosed cable adapters (image10) if necessary. Move the connector housing using the sheet metal holder.

Optimisez le cheminement des câbles, prolongez-les si nécessaire à l'aide des adaptateurs de câbles fournis (l'image10). Déplacer le boîtier du connecteur à l'aide du support en tôle.

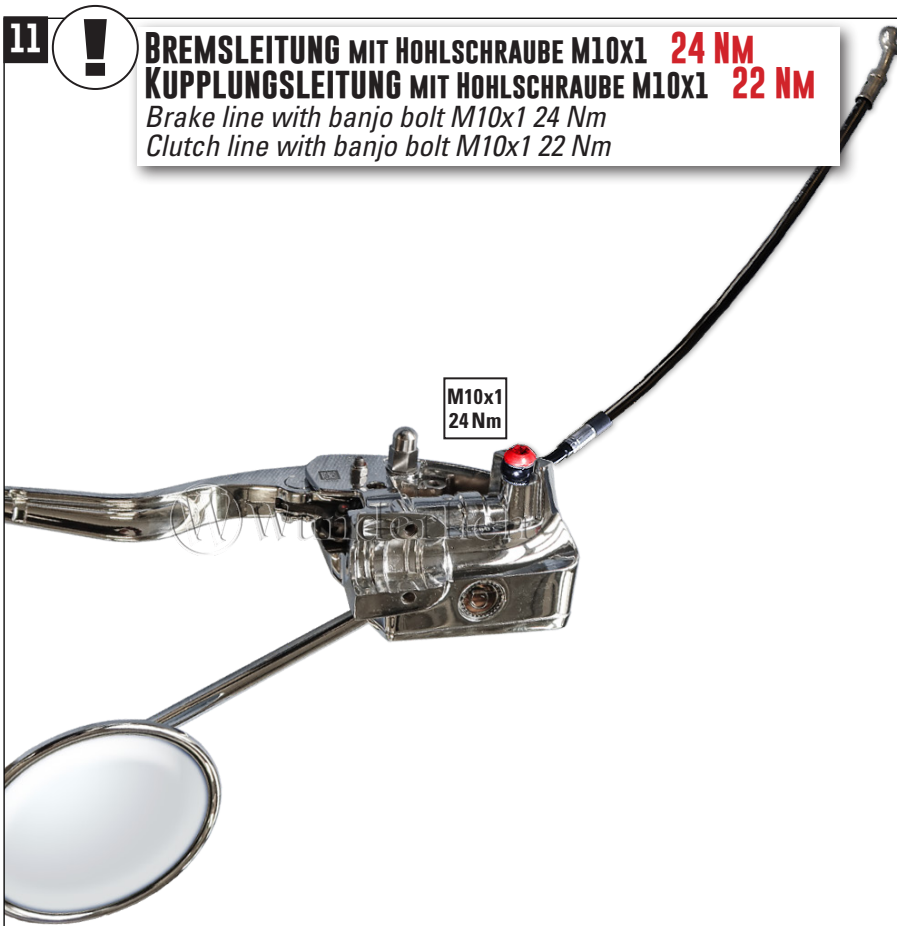

DIE LÄNGEREN BREMS.- UND KUPPLUNGSLEITUNGSLEITUNGEN MONTIEREN UND NACH HERSTELLERANGABEN ENTLÜFTEN. KABELBAUM EINFÄDELN.

Fit the longer brake and clutch lines and bleed them according to the manufacturer's instructions. Threading the cable harness

Installez les conduites de frein et d'embrayage plus longues et purgez-les conformément aux instructions du fabricant. Enfiler le faisceau de câbles

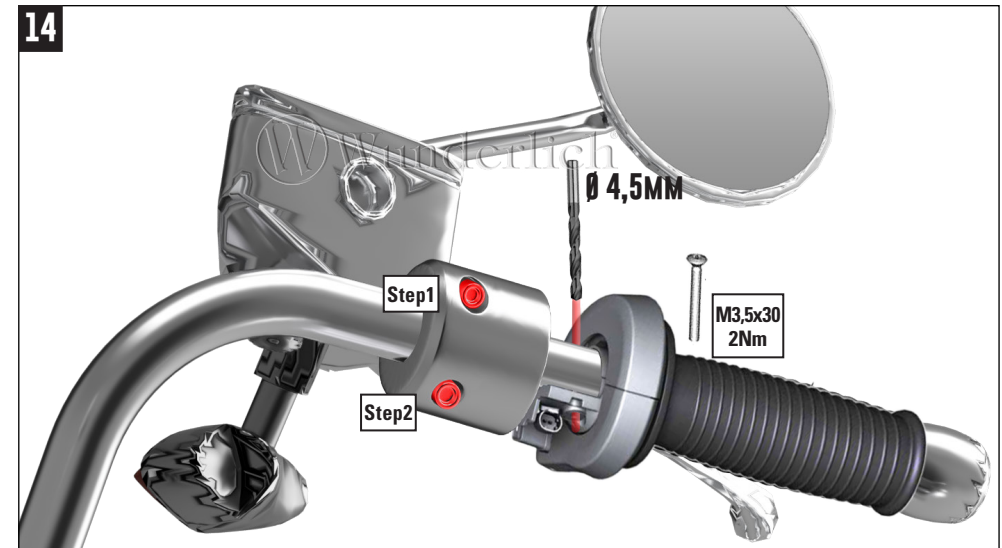
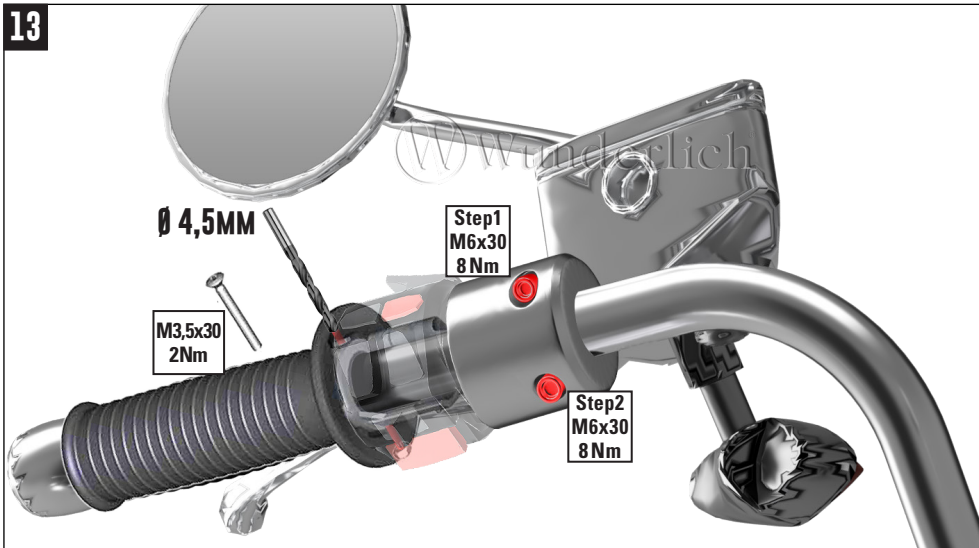

LENKER, KUPPLUNGS.- UND BREMSARMATUR AUSRICHTEN. DIE BEFESTIGUNGEN DER GRIFFEINHEITEN MARKIEREN UND BOHERN. EINGEFÄDELTEN KABELBAUM ANSCHLIEßEN.

Align the handlebars, clutch and brake assembly. Mark and drill the fastenings of the grip units. Connect the threaded wiring harness.
Alignez le guidon, l'embrayage et le frein. Marquez et percez les fixations des unités de prise. Connectez le faisceau de câbles filetés.

