

ZYLINDERKOPFSCHUTZ

Cylinder head protection | Protection cache culbuteur | Protector de culata | Protezione per testata

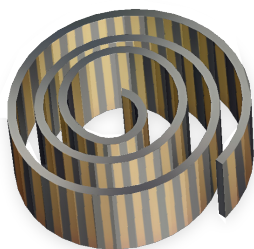

Art.-Nr: 41871-40x



6

LEGENDE/KEY/FILE LÉGENDE

Anbautipp
Fitting tip
Astuce de montage

Schraube
Screw
Vis

Achtung
Attention
Attention

Schraubensicherung
Thread locking fluid
Freinfiles

Vergrößerung
Magnification
Grossissement

Drehmoment
Torque
Torque

Montagepaste
Fitting lubricant
Lubrifiant de montage



#	BEZEICHNUNG / DE DESCRIPTION	Die Farben der Abbildungen dienen nur der Veranschaulichung. The colors are for illustrating purposes only. Les couleurs utilisées sont à titre indicatif seulement.	DIN	ISO	MENGE- AMOUNT
1	Zylinderkopfschutz (links) / Cylinder head protection (left side)				1
2	Zylinderkopfschutz (rechts) / Cylinder head protection (right side)				1
3	Klemmblech / retaining plate				4
4	Senkkopfschraube / countersunk screw (M5x16)				8
5	Moosgummi / foam rubber				100cm

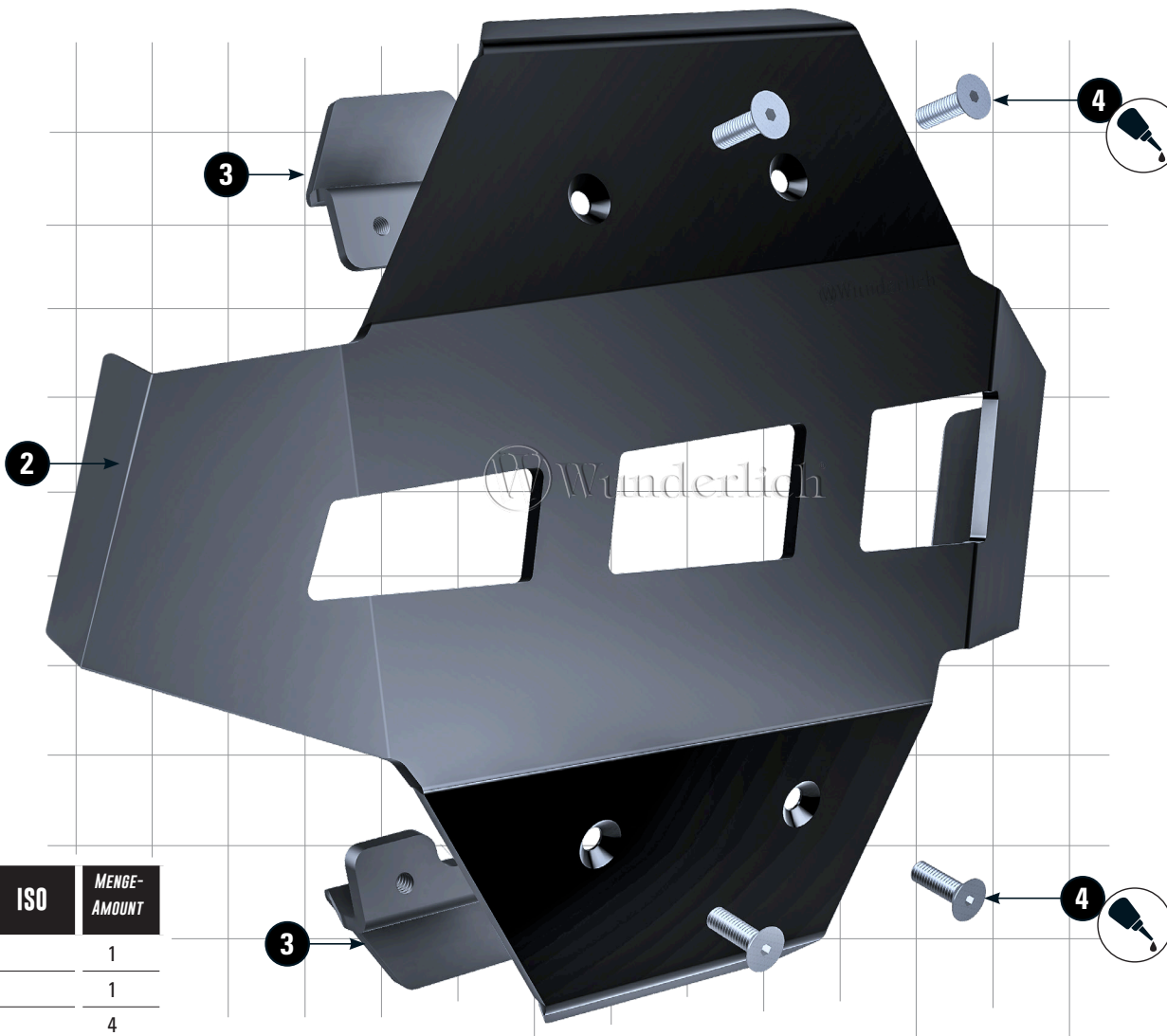

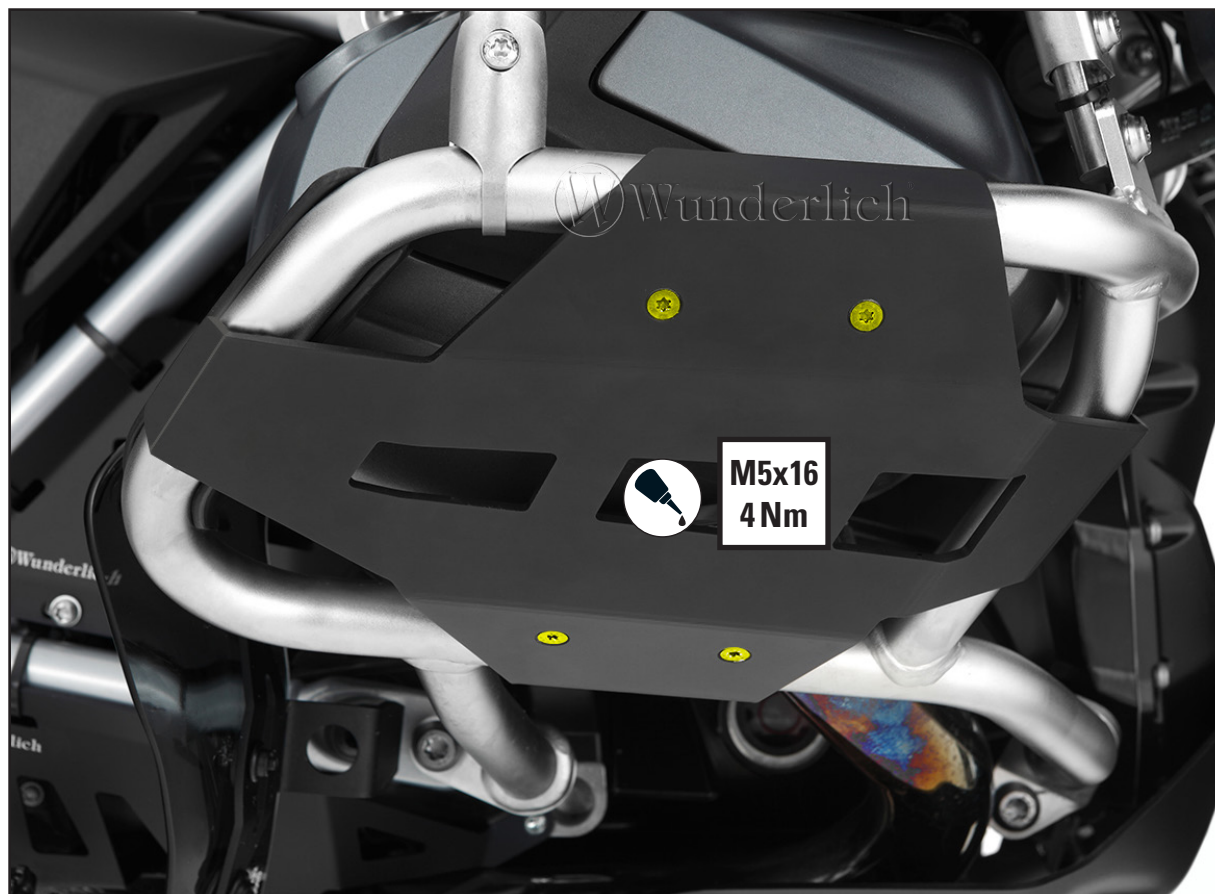
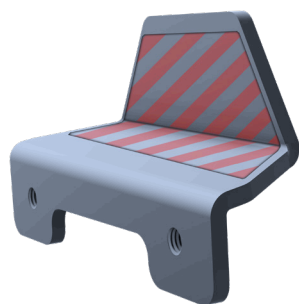
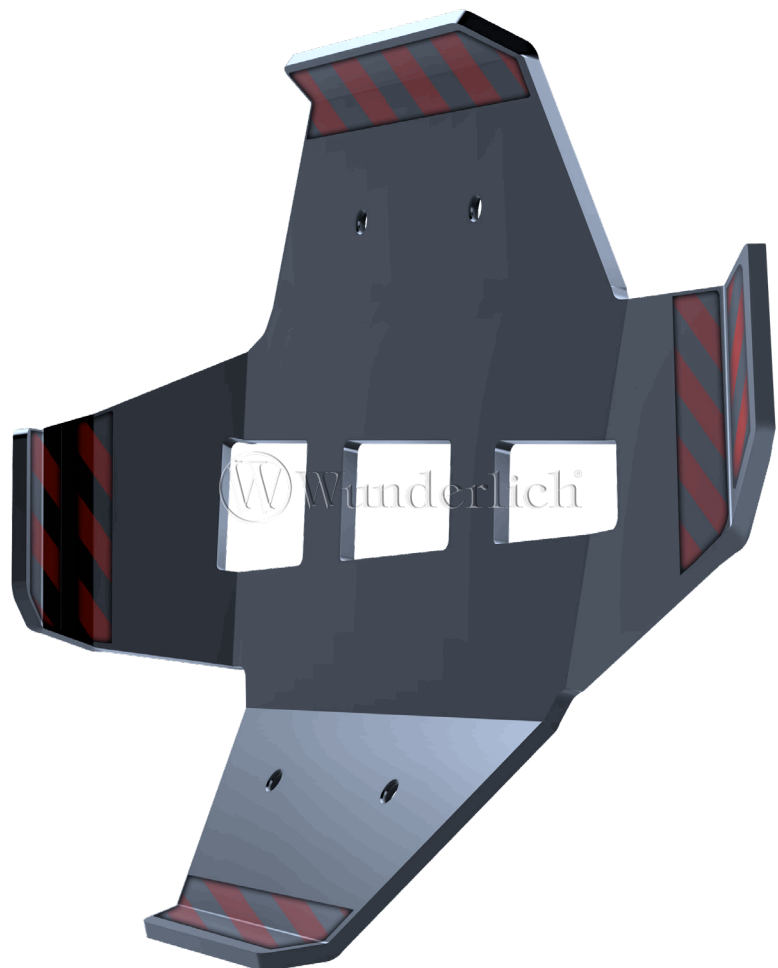

Vor dem Festziehen den korrekten Sitz des Zylinderkopfschutzes zum Motorschutzbügel überprüfen.

Before tightening, check that the cylinder head protection is correctly positioned on the engine protection bar.

Avant de serrer, vérifier que la protection de la culasse est correctement positionnée sur le pare cylindre.



Die am Motorschutzbügel anliegenden Stellen wie dargestellt mit Moosgummi versehen.

Protect the contact points to the engine protection bar as shown with foam rubber.



Protégez les points de contact avec la barre de protection du moteur comme indiqué avec du caoutchouc mousse.