

BREMSHEBELVERGRÖßERUNG

Brake lever extension | Ampliación de pedal de freno | Extension de levier de frein | Estensione della leva del freno







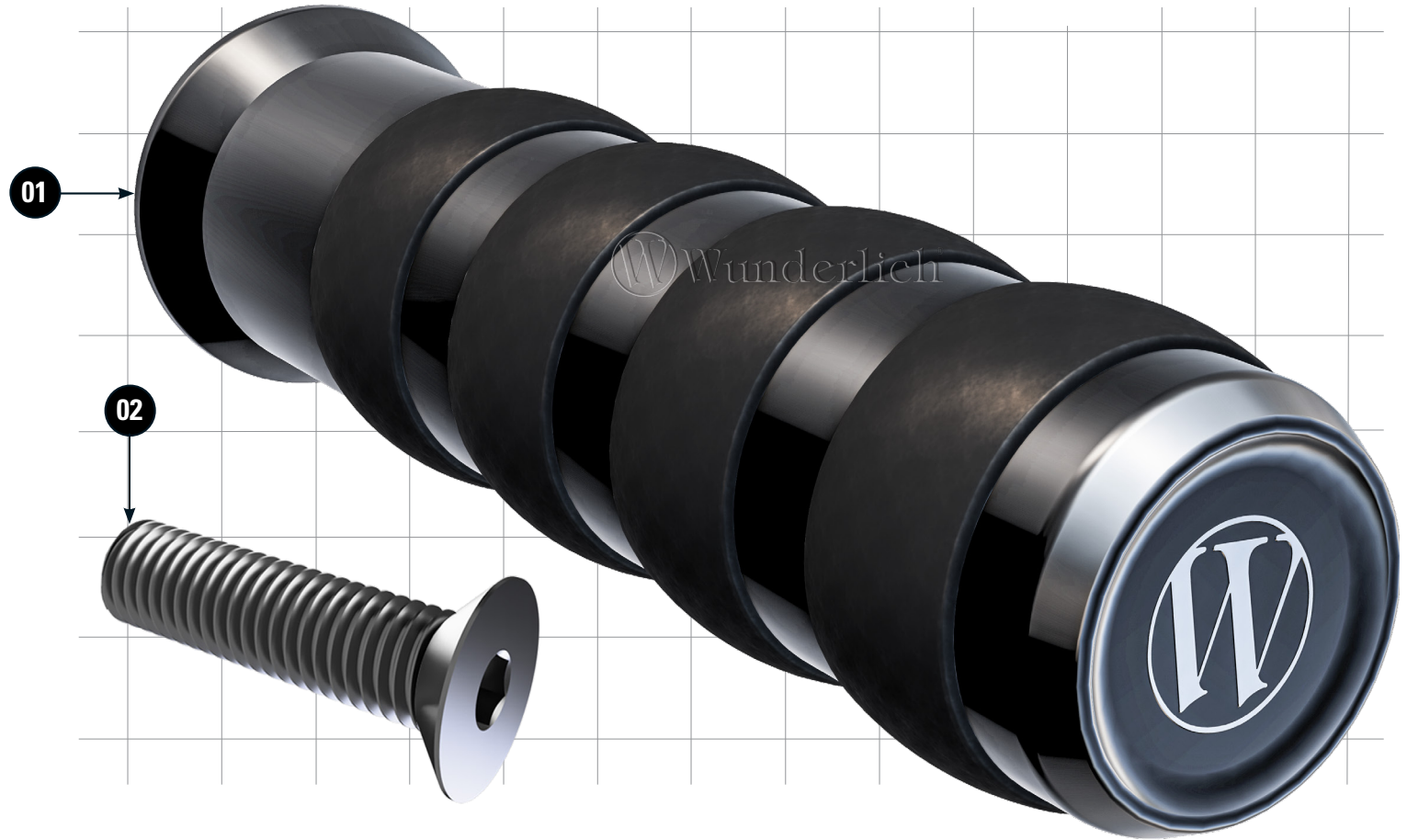

DE Die Farben der Abbildungen dienen nur der Veranschaulichung.
EN The colors are for illustrating purposes only.
FR Les couleurs utilisées sont à titre indicatif seulement.

Artikel.-Nr: **18200-10X**

REV01



LEGENDE/KEY/FILE LÉGENDE

-  **Anbau Tipp**
Fitting tip
Astuce de montage
-  **Achtung**
Attention
Attention
-  **Vergrößerung**
Magnification
Grossissement
-  **Montagepaste**
Fitting lubricant
Lubrifiant de montage
-  **Zusammenbauen**
Assemble
Assembler
-  **Schraubensicherung**
Thread locking fluid
Freinilets
-  **Drehmoment**
Torque
Torque
-  **Gummi Hammer**
Rubber Hammer
Marteau en caoutchouc

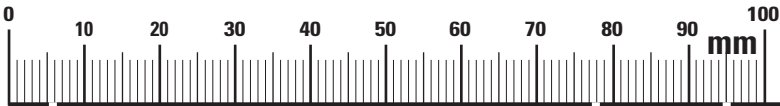

	BEZEICHNUNG / DESCRIPTION	DIN	ISO	MENGE QUANTITY
1	Bremshebelvergrößerung / Brake lever extension			1
2	Senkkopfschraube / lens head screw M8 x 45	7991	10642	1

DIE NR. 1 WELTWEIT FÜR HOCHWERTIGES BMW MOTORRADZUBEHÖR.

01



Wunderlich
complete your BMW.

01

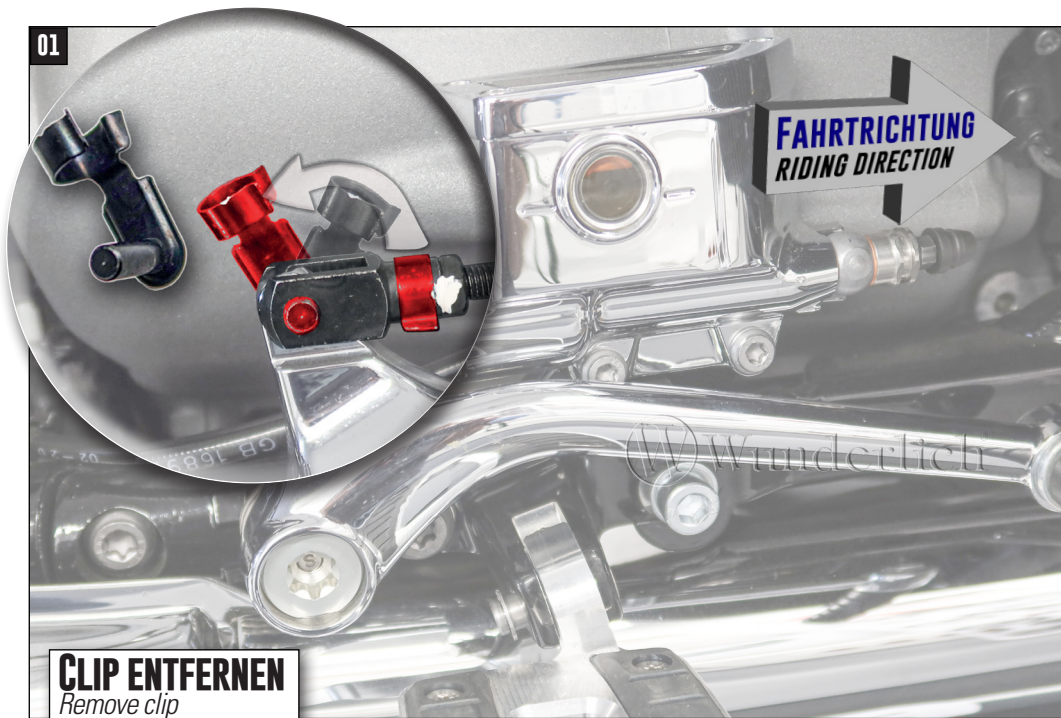

CLIP ENTFERNEN
 Remove clip
 Retirer le clip

02

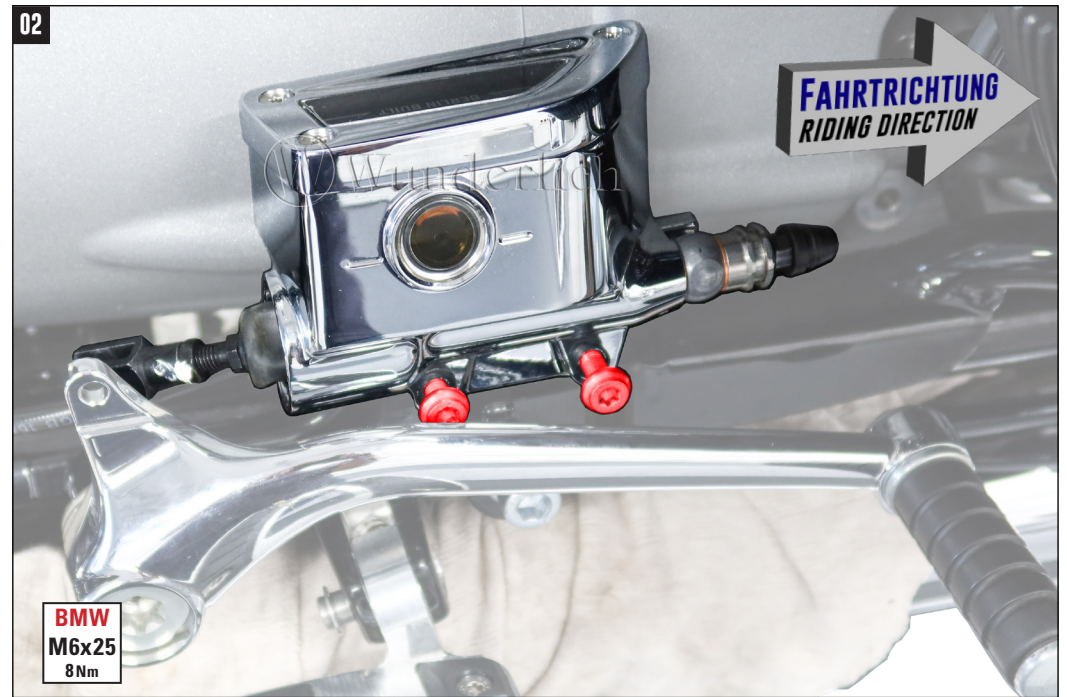

BMW
 M6x25
 8 Nm

03



BMW
 M10x30
 56 Nm

4.1

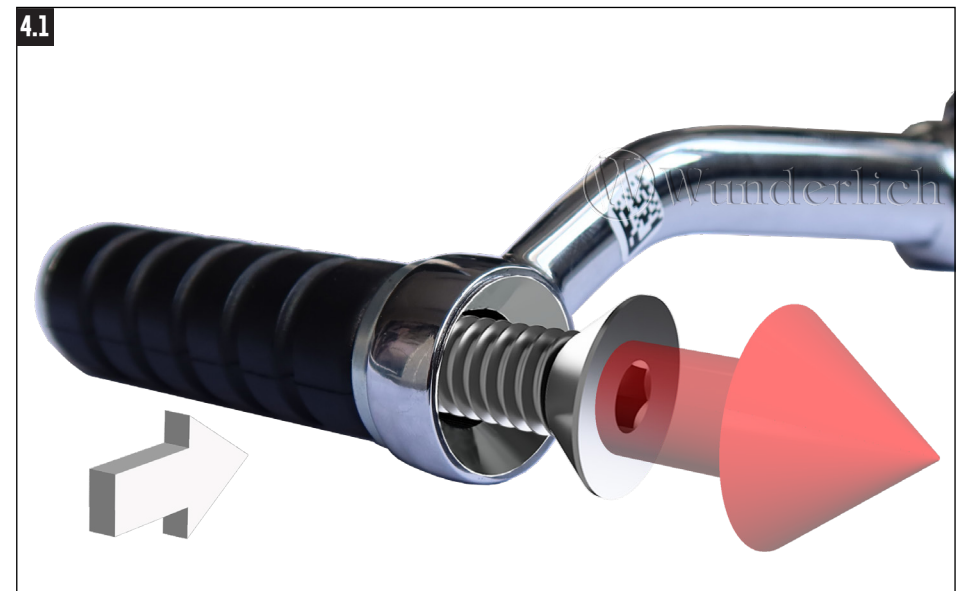

4.2

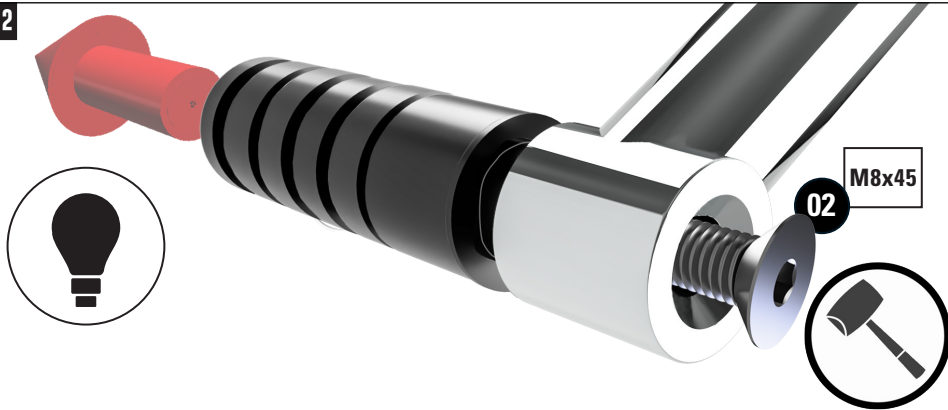

Schraube M8x45 wird nur zum Austreiben bzw. -pressen des orig. Hebels benötigt. Um das Austreiben / -pressen zu erleichtern und Schäden an der Beschichtung zu vermeiden, empfehlen wir das vorherige Erwärmen der Hebelaufnahme.

M8x45 screw is only needed to drive out or press out the original lever. To make the driving out / pressing out easier and to avoid damage to the coating, we recommend heating the lever mount before.

La vis M8x45 n'est nécessaire que pour extraire ou repousser le levier d'origine. Pour faciliter l'extraction et éviter d'endommager le revêtement, nous vous recommandons de chauffer le support du levier avant de l'extraire.

05

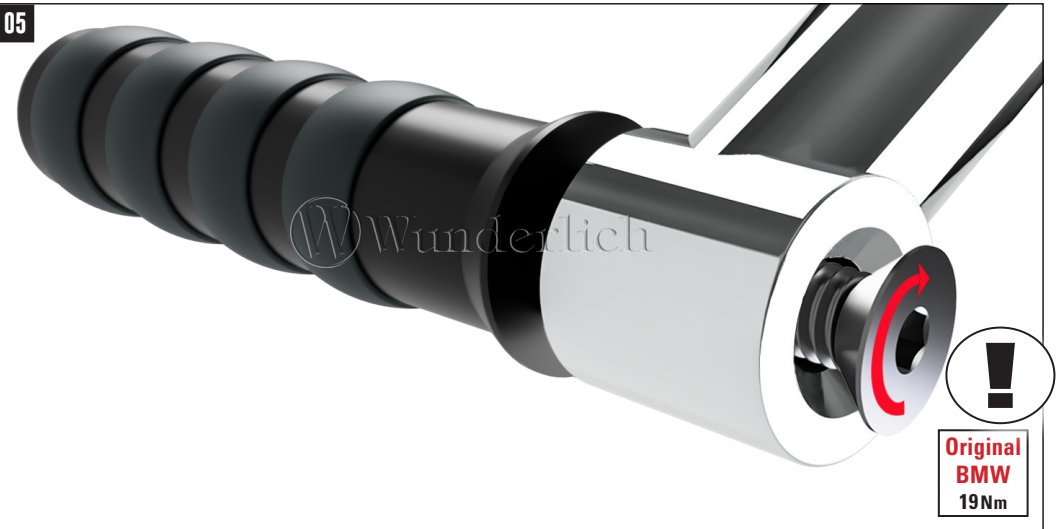

**Original
BMW
19 Nm**

06

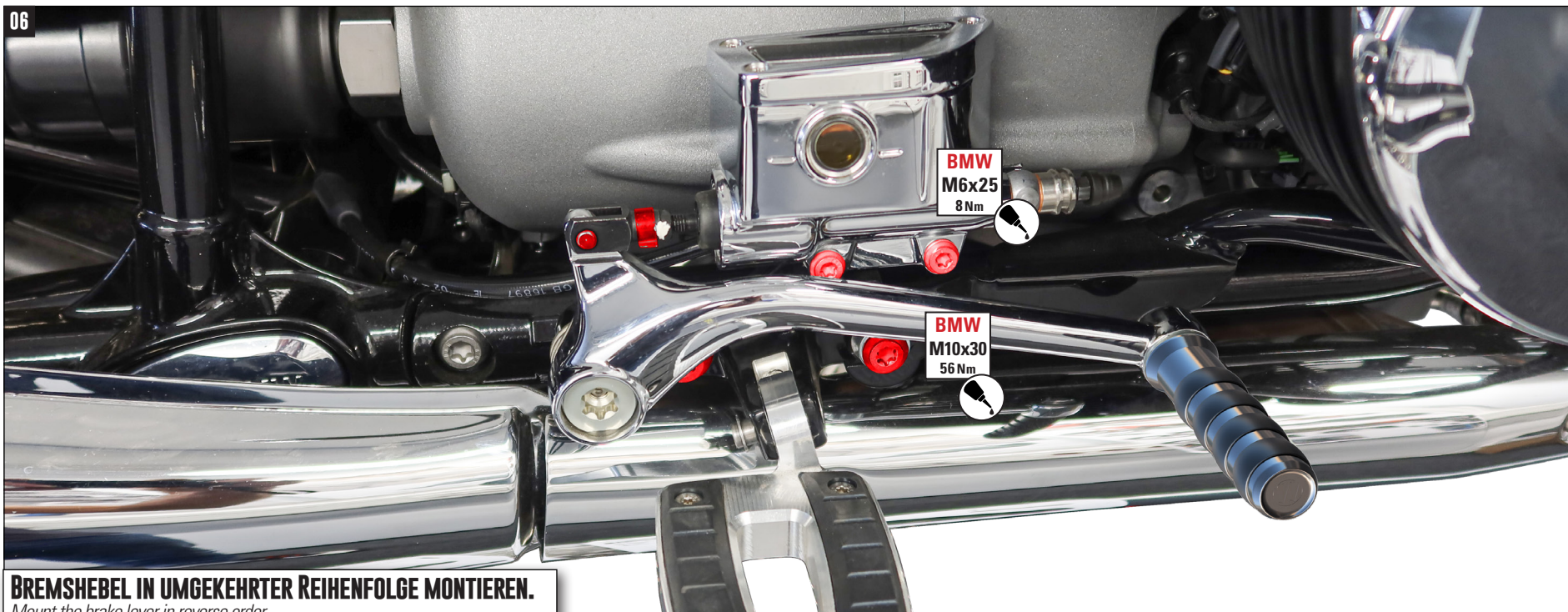

BREMSHEBEL IN UMGEKEHRTER REIHENFOLGE MONTIEREN.

Mount the brake lever in reverse order.

Montez le levier de frein dans l'ordre inverse.