

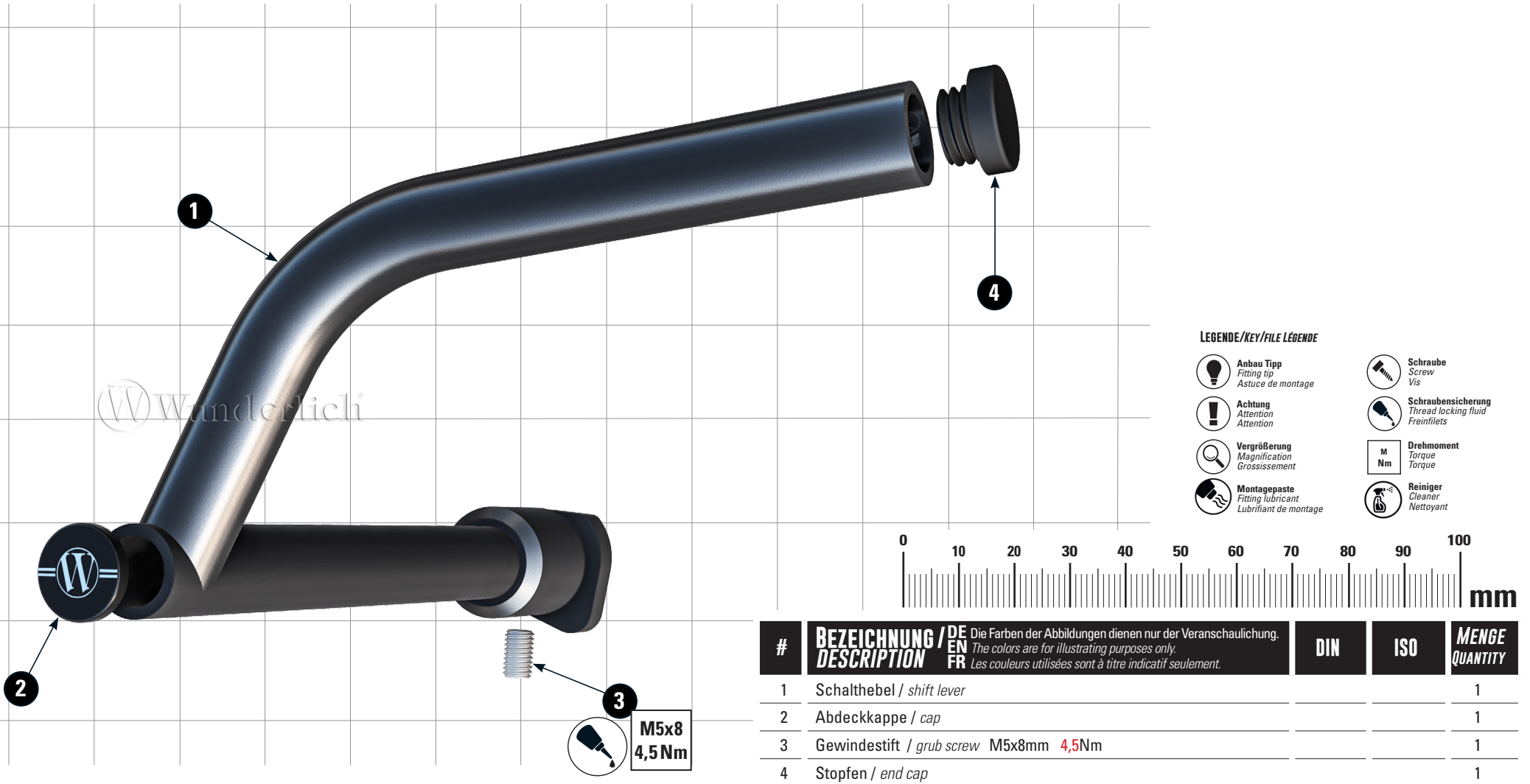







SCHALTHEBEL

shift lever | levier de vitesse | palancas de cambio | leva del cambio

Art.-Nr: 18210-00x



LEGENDE/KEY/FILE LÉGENDE

- | | |
|--|--|
|  Anbau Tipp
Fitting tip
Astuce de montage |  Schraube
Screw
Vis |
|  Achtung
Attention
Attention |  Schraubensicherung
Thread locking fluid
Freinfilets |
|  Vergrößerung
Magnification
Grossissement |  Drehmoment
Torque
Torque |
|  Montagepaste
Fitting lubricant
Lubrifiant de montage |  Reiniger
Cleaner
Nettoyant |

#	BEZEICHNUNG / DESCRIPTION DE / EN / FR	Die Farben der Abbildungen dienen nur der Veranschaulichung. The colors are for illustrating purposes only. Les couleurs utilisées sont à titre indicatif seulement.	DIN	ISO	MENGE / QUANTITY
1	Schalthebel / shift lever				1
2	Abdeckkappe / cap				1
3	Gewindestift / grub screw	M5x8mm 4,5Nm			1
4	Stopfen / end cap				1

